

# LAVORO

Height Adjustable Specialists



DESIGNERS AND  
MANUFACTURERS OF HEIGHT  
ADJUSTABLE FURNITURE

LAVORO



LAVORO

# HEIGHT ADJUSTABLE DESK MANUFACTURERS & SPECIALISTS

VIEW PRODUCTS



At Lavoro, we are 100% committed to supplying quality products at the right price, at the right time.

Our range of high quality height adjustable desks are designed to offer all needs, from executive office desks to state of the art electric height adjustable power desks. We can also create bespoke desks, offering frame options to match any colour scheme.



WELCOME TO LAVORO

## WE ARE SPECIALISTS IN HEIGHT ADJUSTABLE AND FLEXIBLE WORK SOLUTIONS.

As part of a group of companies in the pharmaceutical, safety and furniture industries, we are committed to providing the highest quality products and using leading technology to make the user safe, healthy and happy.

Why choose Lavoro? Benefits include:

- > Next day delivery
- > Huge range
- > Made-to-measure options

Our head office is situated in Newtown, in the heart of Mid Wales where we also have over 20,000 sqft warehousing and CNC Manufacturing facilities.

We are committed to finding the best solution for each project, whether it be through bespoke sizing, colouring or design.

A happy, healthy workforce is a productive workforce. That is why architects and designers worldwide are specifying Lavoro height adjustable desks on office projects worldwide, as an investment into the people who make the business work from day to day. If you are interested in becoming a dealer, or would like help with specifying our products, call us on **0330 133 1112** to find out more.

Warm Regards,



Brent Simpson  
*Managing Director*

## WHY USE HEIGHT ADJUSTABLE FURNITURE?

Spending extended periods of time sitting or standing can be considered a sedentary occupation; therefore the answer must be to move more and vary the position in which we work. Height adjustable furniture allows you to seamlessly switch between standing and sitting in a matter of seconds, keeping you active. They also have the following benefits:

- > **Improved health and wellbeing**  
While sitting for long hours can increase health risks, height adjustable furniture allows you to break this cycle and can help reduce the risk of back pain, osteoporosis, heart disease, diabetes, hypertension and fatigue.
- > **Improved quality of sleep**  
Lack of movement throughout the day can make it more difficult to sleep at night, so alternating between sitting and standing can help you sleep better.
- > **Increased innovation and productivity**  
Height adjustable furniture adds energy to your workplace culture; it revolutionises workplace dynamics, allowing you to focus and work more efficiently. In addition, it enhances the mood and tone of office aesthetics, contributing to higher energy levels.
- > **Advanced ergonomics, flexibility and versatility**  
It ensures you can support an extensive range of different users and uses. This can increase the functionality of your workspace and in turn, increase your output.
- > **Visible diversity and conformity**  
Height adjustable furniture helps you to cater for the needs of disabled persons, wheelchair users and persons with various medical conditions. By helping you to position both the computer and its user safely and comfortably at the optimum height, it also assists you in complying with DSE regulations.



# CONTENTS



---

Advance 8



---

Duo 38

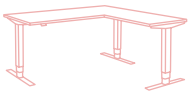

---

Advance Corner 14

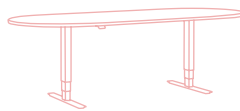

---

Advance Meeting D End 44

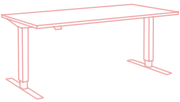

---

Edge 20

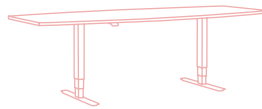

---

Advance Meeting Barrel End 48

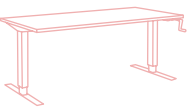

---

Solo 26

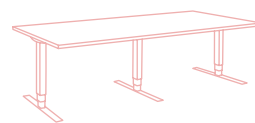

---

Team 52

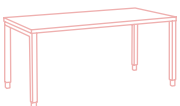

---

Crown 32

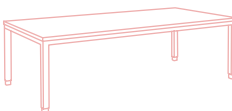

---

Collaborate 56

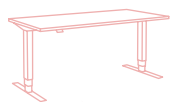



---

Forge 60

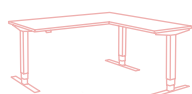

---

Form 80



---

Forge Corner 64



---

Desk Finishes 84



---

Boost 68



---

Accessories 89



---

Flex 72

---

Delivery 102

---

Installation 103

---

Marketing Support 104

---

Production 105

---

Environmental Policy 106



---

Vault 76

---

Terms & Conditions 110



# ADVANCE

## DUAL MOTOR

The Advance height adjustable desk features a sturdy and high quality dual motor system, with anti-collision motors and many accessory options. This desk has the largest height variation in the range, making it great for standing even for the tallest of your workforce. It also will lower to 640mm, making it perfect for wheelchair users and broadens the potential of use in any environment.

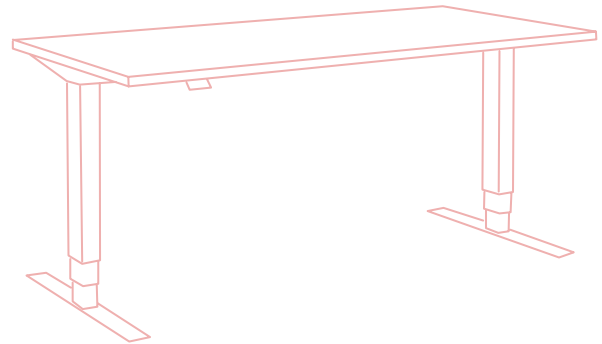

White  
RAL 9016



Silver  
RAL 9006



Black  
RAL 9005

> Dual Motor Desk

> Next Day Delivery

> 5 Year Guarantee

## PRODUCT DETAILS

Guarantee

**5yrs**

Frame Widths

**1150mm - 1740mm**

Side Supports

**540mm**

Leg Size

**690mm**

Load Capacity

**120kg**

Frame Weight

**32kg**

Life

**10,000 cycles at full rated load**

Height Range

**640mm-1300mm**

Voltage

**230V AC Input, 24V DC operation**

Speed

**40mm per second**

Standby Power

**<0.3 W**

Max Operational Power

**300W**

Overload Protection

**Yes**

Thermal Protection

**Yes**

Anti-Collision

**Yes**

Duty Cycle

**10% - 2mins on, 18mins off**

Noise Level

**<42 dB**

CE Compliance

**Machine Directive 2006/42/EC,**

**EMC Directive 2014/30EU**



ADVANCE SILVER FRAME WITH  
1600X800MM WENGE TOP



HIGH QUALITY DUAL  
MOTOR SYSTEM



# ADVANCE SILVER FRAMES



BEECH  
Silver Frame

1200x800:	<a href="#">SADVS/1200800BEE</a>
1400x800:	<a href="#">SADVS/1400800BEE</a>
1600x800:	<a href="#">SADVS/1600800BEE</a>
1800x800:	<a href="#">SADVS/1800800BEE</a>



GREY NEBRASKA OAK  
Silver Frame

1200x800:	<a href="#">SADVS/1200800GNO</a>
1400x800:	<a href="#">SADVS/1400800GNO</a>
1600x800:	<a href="#">SADVS/1600800GNO</a>
1800x800:	<a href="#">SADVS/1800800GNO</a>



GREY  
Silver Frame

1200x800:	<a href="#">SADVS/1200800GRY</a>
1400x800:	<a href="#">SADVS/1400800GRY</a>
1600x800:	<a href="#">SADVS/1600800GRY</a>
1800x800:	<a href="#">SADVS/1800800GRY</a>



MAPLE  
Silver Frame

1200x800:	<a href="#">SADVS/1200800MAP</a>
1400x800:	<a href="#">SADVS/1400800MAP</a>
1600x800:	<a href="#">SADVS/1600800MAP</a>
1800x800:	<a href="#">SADVS/1800800MAP</a>



OAK  
Silver Frame

1200x800:	<a href="#">SADVS/1200800OAK</a>
1400x800:	<a href="#">SADVS/1400800OAK</a>
1600x800:	<a href="#">SADVS/1600800OAK</a>
1800x800:	<a href="#">SADVS/1800800OAK</a>



WALNUT  
Silver Frame

1200x800:	<a href="#">SADVS/1200800WAL</a>
1400x800:	<a href="#">SADVS/1400800WAL</a>
1600x800:	<a href="#">SADVS/1600800WAL</a>
1800x800:	<a href="#">SADVS/1800800WAL</a>



WENGE  
Silver Frame

1200x800:	<a href="#">SADVS/1200800WEN</a>
1400x800:	<a href="#">SADVS/1400800WEN</a>
1600x800:	<a href="#">SADVS/1600800WEN</a>
1800x800:	<a href="#">SADVS/1800800WEN</a>



WHITE  
Silver Frame

1200x800:	<a href="#">SADVS/1200800WHI</a>
1400x800:	<a href="#">SADVS/1400800WHI</a>
1600x800:	<a href="#">SADVS/1600800WHI</a>
1800x800:	<a href="#">SADVS/1800800WHI</a>



CARBON MARINE WOOD  
Silver Frame

1200x800:	<a href="#">SADVS/1200800CMW</a>
1400x800:	<a href="#">SADVS/1400800CMW</a>
1600x800:	<a href="#">SADVS/1600800CMW</a>
1800x800:	<a href="#">SADVS/1800800CMW</a>



BLACK  
Silver Frame

1200x800:	<a href="#">SADVS/1200800BLA</a>
1400x800:	<a href="#">SADVS/1400800BLA</a>
1600x800:	<a href="#">SADVS/1600800BLA</a>
1800x800:	<a href="#">SADVS/1800800BLA</a>



GRAPHITE  
Silver Frame

1200x800:	<a href="#">SADVS/1200800GRA</a>
1400x800:	<a href="#">SADVS/1400800GRA</a>
1600x800:	<a href="#">SADVS/1600800GRA</a>
1800x800:	<a href="#">SADVS/1800800GRA</a>



TIMBER  
Silver Frame

1200x800:	<a href="#">SADVS/1200800TIM</a>
1400x800:	<a href="#">SADVS/1400800TIM</a>
1600x800:	<a href="#">SADVS/1600800TIM</a>
1800x800:	<a href="#">SADVS/1800800TIM</a>



## ADVANCE WHITE FRAMES



BEECH  
White Frame

1200x800: [WADVS/1200800BEE](#)  
 1400x800: [WADVS/1400800BEE](#)  
 1600x800: [WADVS/1600800BEE](#)  
 1800x800: [WADVS/1800800BEE](#)



GREY NEBRASKA OAK  
White Frame

1200x800: [WADVS/1200800GNO](#)  
 1400x800: [WADVS/1400800GNO](#)  
 1600x800: [WADVS/1600800GNO](#)  
 1800x800: [WADVS/1800800GNO](#)



GREY  
White Frame

1200x800: [WADVS/1200800GRY](#)  
 1400x800: [WADVS/1400800GRY](#)  
 1600x800: [WADVS/1600800GRY](#)  
 1800x800: [WADVS/1800800GRY](#)



MAPLE  
White Frame

1200x800: [WADVS/1200800MAP](#)  
 1400x800: [WADVS/1400800MAP](#)  
 1600x800: [WADVS/1600800MAP](#)  
 1800x800: [WADVS/1800800MAP](#)



OAK  
White Frame

1200x800: [WADVS/1200800OAK](#)  
 1400x800: [WADVS/1400800OAK](#)  
 1600x800: [WADVS/1600800OAK](#)  
 1800x800: [WADVS/1800800OAK](#)



WALNUT  
White Frame

1200x800: [WADVS/1200800WAL](#)  
 1400x800: [WADVS/1400800WAL](#)  
 1600x800: [WADVS/1600800WAL](#)  
 1800x800: [WADVS/1800800WAL](#)



WENGE  
White Frame

1200x800: [WADVS/1200800WEN](#)  
 1400x800: [WADVS/1400800WEN](#)  
 1600x800: [WADVS/1600800WEN](#)  
 1800x800: [WADVS/1800800WEN](#)



WHITE  
White Frame

1200x800: [WADVS/1200800WHI](#)  
 1400x800: [WADVS/1400800WHI](#)  
 1600x800: [WADVS/1600800WHI](#)  
 1800x800: [WADVS/1800800WHI](#)



CARBON MARINE WOOD  
White Frame

1200x800: [WADVS/1200800CMW](#)  
 1400x800: [WADVS/1400800CMW](#)  
 1600x800: [WADVS/1600800CMW](#)  
 1800x800: [WADVS/1800800CMW](#)



BLACK  
White Frame

1200x800: [WADVS/1200800BLA](#)  
 1400x800: [WADVS/1400800BLA](#)  
 1600x800: [WADVS/1600800BLA](#)  
 1800x800: [WADVS/1800800BLA](#)



GRAPHITE  
White Frame

1200x800: [WADVS/1200800GRA](#)  
 1400x800: [WADVS/1400800GRA](#)  
 1600x800: [WADVS/1600800GRA](#)  
 1800x800: [WADVS/1800800GRA](#)



TIMBER  
White Frame

1200x800: [WADVS/1200800TIM](#)  
 1400x800: [WADVS/1400800TIM](#)  
 1600x800: [WADVS/1600800TIM](#)  
 1800x800: [WADVS/1800800TIM](#)



# ADVANCE BLACK FRAMES



BEECH  
Black Frame

1200x800: [BADVS/1200800BEE](#)  
 1400x800: [BADVS/1400800BEE](#)  
 1600x800: [BADVS/1600800BEE](#)  
 1800x800: [BADVS/1800800BEE](#)



GREY NEBRASKA OAK  
Black Frame

1200x800: [BADVS/1200800GNO](#)  
 1400x800: [BADVS/1400800GNO](#)  
 1600x800: [BADVS/1600800GNO](#)  
 1800x800: [BADVS/1800800GNO](#)



GREY  
Black Frame

1200x800: [BADVS/1200800GRY](#)  
 1400x800: [BADVS/1400800GRY](#)  
 1600x800: [BADVS/1600800GRY](#)  
 1800x800: [BADVS/1800800GRY](#)



MAPLE  
Black Frame

1200x800: [BADVS/1200800MAP](#)  
 1400x800: [BADVS/1400800MAP](#)  
 1600x800: [BADVS/1600800MAP](#)  
 1800x800: [BADVS/1800800MAP](#)



OAK  
Black Frame

1200x800: [BADVS/1200800OAK](#)  
 1400x800: [BADVS/1400800OAK](#)  
 1600x800: [BADVS/1600800OAK](#)  
 1800x800: [BADVS/1800800OAK](#)



WALNUT  
Black Frame

1200x800: [BADVS/1200800WAL](#)  
 1400x800: [BADVS/1400800WAL](#)  
 1600x800: [BADVS/1600800WAL](#)  
 1800x800: [BADVS/1800800WAL](#)



WENGE  
Black Frame

1200x800: [BADVS/1200800WEN](#)  
 1400x800: [BADVS/1400800WEN](#)  
 1600x800: [BADVS/1600800WEN](#)  
 1800x800: [BADVS/1800800WEN](#)



WHITE  
Black Frame

1200x800: [BADVS/1200800WHI](#)  
 1400x800: [BADVS/1400800WHI](#)  
 1600x800: [BADVS/1600800WHI](#)  
 1800x800: [BADVS/1800800WHI](#)



CARBON MARINE WOOD  
Black Frame

1200x800: [BADVS/1200800CMW](#)  
 1400x800: [BADVS/1400800CMW](#)  
 1600x800: [BADVS/1600800CMW](#)  
 1800x800: [BADVS/1800800CMW](#)



BLACK  
Black Frame

1200x800: [BADVS/1200800BLA](#)  
 1400x800: [BADVS/1400800BLA](#)  
 1600x800: [BADVS/1600800BLA](#)  
 1800x800: [BADVS/1800800BLA](#)



GRAPHITE  
Black Frame

1200x800: [BADVS/1200800GRA](#)  
 1400x800: [BADVS/1400800GRA](#)  
 1600x800: [BADVS/1600800GRA](#)  
 1800x800: [BADVS/1800800GRA](#)



TIMBER  
Black Frame

1200x800: [BADVS/1200800TIM](#)  
 1400x800: [BADVS/1400800TIM](#)  
 1600x800: [BADVS/1600800TIM](#)  
 1800x800: [BADVS/1800800TIM](#)



# ADVANCE CORNER DESK

## TRIPLE MOTOR

The Advance Corner height adjustable desk has all of the advantages of the popular Advance desk, with a smooth-operating triple motor system and anti-collision safety features as standard. Perfect for executive use, giving extra workspace for printers and storage.

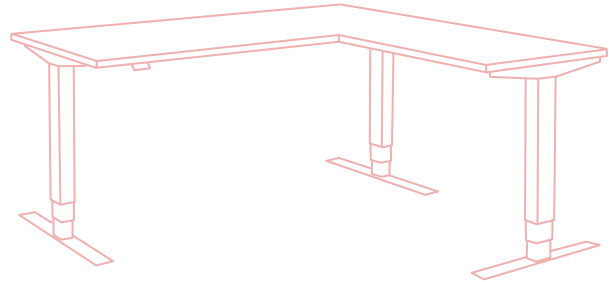

White  
RAL 9016



Silver  
RAL 9006



Black  
RAL 9005

> Triple Motor Desk

> Next Day Delivery

> 5 Year Guarantee

## PRODUCT DETAILS

Guarantee

**5yrs**

Frame Width Adjustment

**1150-1740mm x 1545-2135mm**

Side Supports (Brackets)

**540mm**

Leg Size

**540mm x 2, 490mm x1**

Load Capacity

**160kg**

Frame Weight

**48kg**

Life

**10,000 cycles at full rated load**

Height Range (stroke)

**640mm-1300mm**

Voltage

**230V AC Input, 24V DC operation**

Speed

**40mm per second**

Standby Power

**<0.3 W**

Max Operational Power

**410W**

Overload Protection

**Yes**

Thermal Protection

**Yes**

Anti-Collision

**Yes**

Duty Cycle

**10% - 2mins on, 18mins off**

Noise Level

**<42 dB**

CE Compliance

**Machine Directive 2006/42/EC,**

**EMC Directive 2014/30EU**

ADVANCE CORNER BLACK FRAME  
WITH 1600X1600MM BEECH TOP

SMOOTH-OPERATING  
TRIPLE MOTOR SYSTEM







## ADVANCE CORNER SILVER FRAMES



BEECH  
Silver Frame

1600x1600: [SADVC/16001600BEE](#)  
1800x1600: [SADVC/18001600BEE](#)



GREY NEBRASKA OAK  
Silver Frame

1600x1600: [SADVC/16001600GNO](#)  
1800x1600: [SADVC/18001600GNO](#)



GREY  
Silver Frame

1600x1600: [SADVC/16001600GRY](#)  
1800x1600: [SADVC/18001600GRY](#)



MAPLE  
Silver Frame

1600x1600: [SADVC/16001600MAP](#)  
1800x1600: [SADVC/18001600MAP](#)



OAK  
Silver Frame

1600x1600: [SADVC/16001600OAK](#)  
1800x1600: [SADVC/18001600OAK](#)



WALNUT  
Silver Frame

1600x1600: [SADVC/16001600WAL](#)  
1800x1600: [SADVC/18001600WAL](#)



WENGE  
Silver Frame

1600x1600: [SADVC/16001600WEN](#)  
1800x1600: [SADVC/18001600WEN](#)



WHITE  
Silver Frame

1600x1600: [SADVC/16001600WHI](#)  
1800x1600: [SADVC/18001600WHI](#)



CARBON MARINE WOOD  
Silver Frame

1600x1600: [SADVC/16001600CMW](#)  
1800x1600: [SADVC/18001600CMW](#)



BLACK  
Silver Frame

1600x1600: [SADVC/16001600BLA](#)  
1800x1600: [SADVC/18001600BLA](#)



GRAPHITE  
Silver Frame

1600x1600: [SADVC/16001600GRA](#)  
1800x1600: [SADVC/18001600GRA](#)



TIMBER  
Silver Frame

1600x1600: [SADVC/16001600TIM](#)  
1800x1600: [SADVC/18001600TIM](#)



# ADVANCE CORNER WHITE FRAMES



BEECH  
White Frame

1600x1600: [WADVC/16001600BEE](#)  
1800x1600: [WADVC/18001600BEE](#)

GREY NEBRASKA OAK  
White Frame

1600x1600: [WADVC/16001600GNO](#)  
1800x1600: [WADVC/18001600GNO](#)

GREY  
White Frame

1600x1600: [WADVC/16001600GRY](#)  
1800x1600: [WADVC/18001600GRY](#)

MAPLE  
White Frame

1600x1600: [WADVC/16001600MAP](#)  
1800x1600: [WADVC/18001600MAP](#)



OAK  
White Frame

1600x1600: [WADVC/16001600OAK](#)  
1800x1600: [WADVC/18001600OAK](#)

WALNUT  
White Frame

1600x1600: [WADVC/16001600WAL](#)  
1800x1600: [WADVC/18001600WAL](#)

WENGE  
White Frame

1600x1600: [WADVC/16001600WEN](#)  
1800x1600: [WADVC/18001600WEN](#)

WHITE  
White Frame

1600x1600: [WADVC/16001600WHI](#)  
1800x1600: [WADVC/18001600WHI](#)



CARBON MARINE WOOD  
White Frame

1600x1600: [WADVC/16001600CMW](#)  
1800x1600: [WADVC/18001600CMW](#)

BLACK  
White Frame

1600x1600: [WADVC/16001600BLA](#)  
1800x1600: [WADVC/18001600BLA](#)

GRAPHITE  
White Frame

1600x1600: [WADVC/16001600GRA](#)  
1800x1600: [WADVC/18001600GRA](#)

TIMBER  
White Frame

1600x1600: [WADVC/16001600TIM](#)  
1800x1600: [WADVC/18001600TIM](#)



## ADVANCE CORNER BLACK FRAMES



BEECH  
Black Frame

1600x1600: [BADVC/16001600BEE](#)  
1800x1600: [BADVC/18001600BEE](#)



GREY NEBRASKA OAK  
Black Frame

1600x1600: [BADVC/16001600GNO](#)  
1800x1600: [BADVC/18001600GNO](#)



GREY  
Black Frame

1600x1600: [BADVC/16001600GRY](#)  
1800x1600: [BADVC/18001600GRY](#)



MAPLE  
Black Frame

1600x1600: [BADVC/16001600MAP](#)  
1800x1600: [BADVC/18001600MAP](#)



OAK  
Black Frame

1600x1600: [BADVC/16001600OAK](#)  
1800x1600: [BADVC/18001600OAK](#)



WALNUT  
Black Frame

1600x1600: [BADVC/16001600WAL](#)  
1800x1600: [BADVC/18001600WAL](#)



WENGE  
Black Frame

1600x1600: [BADVC/16001600WEN](#)  
1800x1600: [BADVC/18001600WEN](#)



WHITE  
Black Frame

1600x1600: [BADVC/16001600WHI](#)  
1800x1600: [BADVC/18001600WHI](#)



CARBON MARINE WOOD  
Black Frame

1600x1600: [BADVC/16001600CMW](#)  
1800x1600: [BADVC/18001600CMW](#)



BLACK  
Black Frame

1600x1600: [BADVC/16001600BLA](#)  
1800x1600: [BADVC/18001600BLA](#)



GRAPHITE  
Black Frame

1600x1600: [BADVC/16001600GRA](#)  
1800x1600: [BADVC/18001600GRA](#)



TIMBER  
Black Frame

1600x1600: [BADVC/16001600TIM](#)  
1800x1600: [BADVC/18001600TIM](#)



# EDGE

## SINGLE MOTOR

The Edge height adjustable desk is the perfect entry level desk for all who require the flexibility of a varying height work surface. With its straightforward, minimalistic design and simple single-motor system (to ensure low cost and reliable operation) the Edge desk is a perfect all-encompassing sit/stand desk solution.

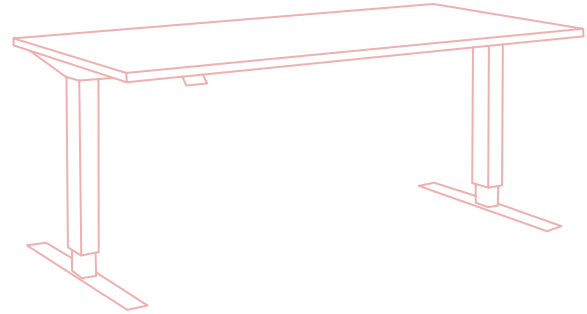

White  
RAL 9016



Silver  
RAL 9006



Black  
RAL 9005

> Single Motor Desk

> Next Day Delivery

> 5 Year Guarantee

## PRODUCT DETAILS

Guarantee

**5yrs**

Frame Width Adjustment

**1150mm-1740mm**

Side Supports (Brackets)

**580mm**

Leg Depth

**690mm**

Load Capacity

**80kg**

Frame Weight

**24kg**

Life

**10,000 cycles at full rated load**

Height Range (stroke)

**710mm-1210mm**

Voltage

**230V AC Input, 24V DC operation**

Speed

**320mm per second**

Standby Power

**<0.3 W**

Max Operational Power

**300W**

Overload Protection

**No**

Thermal Protection

**Yes**

Anti-Collision

**No**

Duty Cycle

**10% - 2mins on, 18mins off**

Noise Level

**<42 dB**

CE Compliance

**Machine Directive 2006/42/EC,**

**EMC Directive 2014/30EU**

EDGE BLACK FRAME WITH  
1600X800MM OAK TOP



PERFECT ENTRY LEVEL  
SIT/STAND DESK SOLUTION



## EDGE SILVER FRAMES



BEECH  
Silver Frame

1200x800: [SEDGS/1200800BEE](#)  
 1400x800: [SEDGS/1400800BEE](#)  
 1600x800: [SEDGS/1600800BEE](#)  
 1800x800: [SEDGS/1800800BEE](#)



GREY NEBRASKA OAK  
Silver Frame

1200x800: [SEDGS/1200800GNO](#)  
 1400x800: [SEDGS/1400800GNO](#)  
 1600x800: [SEDGS/1600800GNO](#)  
 1800x800: [SEDGS/1800800GNO](#)



GREY  
Silver Frame

1200x800: [SEDGS/1200800GRY](#)  
 1400x800: [SEDGS/1400800GRY](#)  
 1600x800: [SEDGS/1600800GRY](#)  
 1800x800: [SEDGS/1800800GRY](#)



MAPLE  
Silver Frame

1200x800: [SEDGS/1200800MAP](#)  
 1400x800: [SEDGS/1400800MAP](#)  
 1600x800: [SEDGS/1600800MAP](#)  
 1800x800: [SEDGS/1800800MAP](#)



OAK  
Silver Frame

1200x800: [SEDGS/1200800OAK](#)  
 1400x800: [SEDGS/1400800OAK](#)  
 1600x800: [SEDGS/1600800OAK](#)  
 1800x800: [SEDGS/1800800OAK](#)



WALNUT  
Silver Frame

1200x800: [SEDGS/1200800WAL](#)  
 1400x800: [SEDGS/1400800WAL](#)  
 1600x800: [SEDGS/1600800WAL](#)  
 1800x800: [SEDGS/1800800WAL](#)



WENGE  
Silver Frame

1200x800: [SEDGS/1200800WEN](#)  
 1400x800: [SEDGS/1400800WEN](#)  
 1600x800: [SEDGS/1600800WEN](#)  
 1800x800: [SEDGS/1800800WEN](#)



WHITE  
Silver Frame

1200x800: [SEDGS/1200800WHI](#)  
 1400x800: [SEDGS/1400800WHI](#)  
 1600x800: [SEDGS/1600800WHI](#)  
 1800x800: [SEDGS/1800800WHI](#)



CARBON MARINE WOOD  
Silver Frame

1200x800: [SEDGS/1200800CMW](#)  
 1400x800: [SEDGS/1400800CMW](#)  
 1600x800: [SEDGS/1600800CMW](#)  
 1800x800: [SEDGS/1800800CMW](#)



BLACK  
Silver Frame

1200x800: [SEDGS/1200800BLA](#)  
 1400x800: [SEDGS/1400800BLA](#)  
 1600x800: [SEDGS/1600800BLA](#)  
 1800x800: [SEDGS/1800800BLA](#)



GRAPHITE  
Silver Frame

1200x800: [SEDGS/1200800GRA](#)  
 1400x800: [SEDGS/1400800GRA](#)  
 1600x800: [SEDGS/1600800GRA](#)  
 1800x800: [SEDGS/1800800GRA](#)



TIMBER  
Silver Frame

1200x800: [SEDGS/1200800TIM](#)  
 1400x800: [SEDGS/1400800TIM](#)  
 1600x800: [SEDGS/1600800TIM](#)  
 1800x800: [SEDGS/1800800TIM](#)





## EDGE WHITE FRAMES



BEECH  
White Frame

1200x800: [WEDGS/1200800BEE](#)  
1400x800: [WEDGS/1400800BEE](#)  
1600x800: [WEDGS/1600800BEE](#)  
1800x800: [WEDGS/1800800BEE](#)



GREY NEBRASKA OAK  
White Frame

1200x800: [WEDGS/1200800GNO](#)  
1400x800: [WEDGS/1400800GNO](#)  
1600x800: [WEDGS/1600800GNO](#)  
1800x800: [WEDGS/1800800GNO](#)



GREY  
White Frame

1200x800: [WEDGS/1200800GRY](#)  
1400x800: [WEDGS/1400800GRY](#)  
1600x800: [WEDGS/1600800GRY](#)  
1800x800: [WEDGS/1800800GRY](#)



MAPLE  
White Frame

1200x800: [WEDGS/1200800MAP](#)  
1400x800: [WEDGS/1400800MAP](#)  
1600x800: [WEDGS/1600800MAP](#)  
1800x800: [WEDGS/1800800MAP](#)



OAK  
White Frame

1200x800: [WEDGS/1200800OAK](#)  
1400x800: [WEDGS/1400800OAK](#)  
1600x800: [WEDGS/1600800OAK](#)  
1800x800: [WEDGS/1800800OAK](#)



WALNUT  
White Frame

1200x800: [WEDGS/1200800WAL](#)  
1400x800: [WEDGS/1400800WAL](#)  
1600x800: [WEDGS/1600800WAL](#)  
1800x800: [WEDGS/1800800WAL](#)



WENGE  
White Frame

1200x800: [WEDGS/1200800WEN](#)  
1400x800: [WEDGS/1400800WEN](#)  
1600x800: [WEDGS/1600800WEN](#)  
1800x800: [WEDGS/1800800WEN](#)



WHITE  
White Frame

1200x800: [WEDGS/1200800WHI](#)  
1400x800: [WEDGS/1400800WHI](#)  
1600x800: [WEDGS/1600800WHI](#)  
1800x800: [WEDGS/1800800WHI](#)



CARBON MARINE WOOD  
White Frame

1200x800: [WEDGS/1200800CMW](#)  
1400x800: [WEDGS/1400800CMW](#)  
1600x800: [WEDGS/1600800CMW](#)  
1800x800: [WEDGS/1800800CMW](#)



BLACK  
White Frame

1200x800: [WEDGS/1200800BLA](#)  
1400x800: [WEDGS/1400800BLA](#)  
1600x800: [WEDGS/1600800BLA](#)  
1800x800: [WEDGS/1800800BLA](#)



GRAPHITE  
White Frame

1200x800: [WEDGS/1200800GRA](#)  
1400x800: [WEDGS/1400800GRA](#)  
1600x800: [WEDGS/1600800GRA](#)  
1800x800: [WEDGS/1800800GRA](#)



TIMBER  
White Frame

1200x800: [WEDGS/1200800TIM](#)  
1400x800: [WEDGS/1400800TIM](#)  
1600x800: [WEDGS/1600800TIM](#)  
1800x800: [WEDGS/1800800TIM](#)



## EDGE BLACK FRAMES



BEECH  
Black Frame

1200x800: [BEDGS/1200800BEE](#)  
 1400x800: [BEDGS/1400800BEE](#)  
 1600x800: [BEDGS/1600800BEE](#)  
 1800x800: [BEDGS/1800800BEE](#)



GREY NEBRASKA OAK  
Black Frame

1200x800: [BEDGS/1200800GNO](#)  
 1400x800: [BEDGS/1400800GNO](#)  
 1600x800: [BEDGS/1600800GNO](#)  
 1800x800: [BEDGS/1800800GNO](#)



GREY  
Black Frame

1200x800: [BEDGS/1200800GRY](#)  
 1400x800: [BEDGS/1400800GRY](#)  
 1600x800: [BEDGS/1600800GRY](#)  
 1800x800: [BEDGS/1800800GRY](#)



MAPLE  
Black Frame

1200x800: [BEDGS/1200800MAP](#)  
 1400x800: [BEDGS/1400800MAP](#)  
 1600x800: [BEDGS/1600800MAP](#)  
 1800x800: [BEDGS/1800800MAP](#)



OAK  
Black Frame

1200x800: [BEDGS/1200800OAK](#)  
 1400x800: [BEDGS/1400800OAK](#)  
 1600x800: [BEDGS/1600800OAK](#)  
 1800x800: [BEDGS/1800800OAK](#)



WALNUT  
Black Frame

1200x800: [BEDGS/1200800WAL](#)  
 1400x800: [BEDGS/1400800WAL](#)  
 1600x800: [BEDGS/1600800WAL](#)  
 1800x800: [BEDGS/1800800WAL](#)



WENGE  
Black Frame

1200x800: [BEDGS/1200800WEN](#)  
 1400x800: [BEDGS/1400800WEN](#)  
 1600x800: [BEDGS/1600800WEN](#)  
 1800x800: [BEDGS/1800800WEN](#)



WHITE  
Black Frame

1200x800: [BEDGS/1200800WHI](#)  
 1400x800: [BEDGS/1400800WHI](#)  
 1600x800: [BEDGS/1600800WHI](#)  
 1800x800: [BEDGS/1800800WHI](#)



CARBON MARINE WOOD  
Black Frame

1200x800: [BEDGS/1200800CMW](#)  
 1400x800: [BEDGS/1400800CMW](#)  
 1600x800: [BEDGS/1600800CMW](#)  
 1800x800: [BEDGS/1800800CMW](#)



BLACK  
Black Frame

1200x800: [BEDGS/1200800BLA](#)  
 1400x800: [BEDGS/1400800BLA](#)  
 1600x800: [BEDGS/1600800BLA](#)  
 1800x800: [BEDGS/1800800BLA](#)



GRAPHITE  
Black Frame

1200x800: [BEDGS/1200800GRA](#)  
 1400x800: [BEDGS/1400800GRA](#)  
 1600x800: [BEDGS/1600800GRA](#)  
 1800x800: [BEDGS/1800800GRA](#)



TIMBER  
Black Frame

1200x800: [BEDGS/1200800TIM](#)  
 1400x800: [BEDGS/1400800TIM](#)  
 1600x800: [BEDGS/1600800TIM](#)  
 1800x800: [BEDGS/1800800TIM](#)



# SOLO

## HAND CRANK

A low maintenance desk with zero energy consumption, the Solo is operated with a manual hand crank. Suitable for applications where power is not easily accessible, or for educational environments. With lightweight construction and no power cable, the Solo is also easy to move freely throughout any working environment.

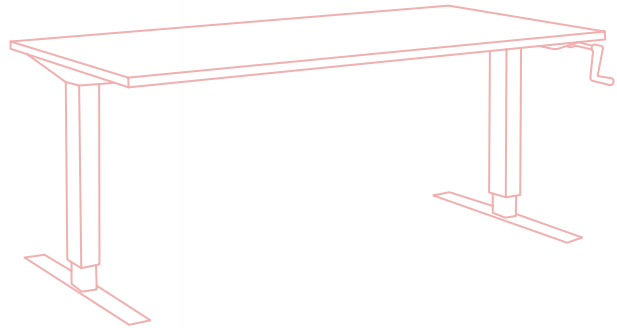

White  
RAL 9016



Silver  
RAL 9006



Black  
RAL 9005

> Hand Crank

> Next Day Delivery

> 5 Year Guarantee

## PRODUCT DETAILS

Guarantee

**5yrs**

Frame Width Adjustment

**1150mm-1740mm**

Side Supports (Brackets)

**580mm**

Leg Depth

**690mm**

Load Capacity

**120kg**

Frame Weight

**26kg**

Life

**N/A**

Height Range (stroke)

**710mm-1210mm**

Voltage

**N/A**

Speed

**N/A**

Standby Power

**N/A**

Max Operational Power

**N/A**

Overload Protection

**N/A**

Thermal Protection

**N/A**

Anti-Collision

**N/A**

Duty Cycle

**N/A**

Noise Level

**N/A**

CE Compliance

**Yes**

VERSATILE STOW-AWAY  
HAND CRANK SYSTEM



SOLO WHITE FRAME WITH  
1600X800MM WENGE TOP

ALSO AVAILABLE WITH  
CASTORS. PLEASE SEE  
ACCESSORY SECTION



## SOLO SILVER FRAMES



BEECH  
Silver Frame

1200x800:	<a href="#">SSOLO/1200800BEE</a>
1400x800:	<a href="#">SSOLO/1400800BEE</a>
1600x800:	<a href="#">SSOLO/1600800BEE</a>
1800x800:	<a href="#">SSOLO/1800800BEE</a>



GREY NEBRASKA OAK  
Silver Frame

1200x800:	<a href="#">SSOLO/1200800GNO</a>
1400x800:	<a href="#">SSOLO/1400800GNO</a>
1600x800:	<a href="#">SSOLO/1600800GNO</a>
1800x800:	<a href="#">SSOLO/1800800GNO</a>



GREY  
Silver Frame

1200x800:	<a href="#">SSOLO/1200800GRY</a>
1400x800:	<a href="#">SSOLO/1400800GRY</a>
1600x800:	<a href="#">SSOLO/1600800GRY</a>
1800x800:	<a href="#">SSOLO/1800800GRY</a>



MAPLE  
Silver Frame

1200x800:	<a href="#">SSOLO/1200800MAP</a>
1400x800:	<a href="#">SSOLO/1400800MAP</a>
1600x800:	<a href="#">SSOLO/1600800MAP</a>
1800x800:	<a href="#">SSOLO/1800800MAP</a>



OAK  
Silver Frame

1200x800:	<a href="#">SSOLO/1200800OAK</a>
1400x800:	<a href="#">SSOLO/1400800OAK</a>
1600x800:	<a href="#">SSOLO/1600800OAK</a>
1800x800:	<a href="#">SSOLO/1800800OAK</a>



WALNUT  
Silver Frame

1200x800:	<a href="#">SSOLO/1200800WAL</a>
1400x800:	<a href="#">SSOLO/1400800WAL</a>
1600x800:	<a href="#">SSOLO/1600800WAL</a>
1800x800:	<a href="#">SSOLO/1800800WAL</a>



WENGE  
Silver Frame

1200x800:	<a href="#">SSOLO/1200800WEN</a>
1400x800:	<a href="#">SSOLO/1400800WEN</a>
1600x800:	<a href="#">SSOLO/1600800WEN</a>
1800x800:	<a href="#">SSOLO/1800800WEN</a>



WHITE  
Silver Frame

1200x800:	<a href="#">SSOLO/1200800WHI</a>
1400x800:	<a href="#">SSOLO/1400800WHI</a>
1600x800:	<a href="#">SSOLO/1600800WHI</a>
1800x800:	<a href="#">SSOLO/1800800WHI</a>



CARBON MARINE WOOD  
Silver Frame

1200x800:	<a href="#">SSOLO/1200800CMW</a>
1400x800:	<a href="#">SSOLO/1400800CMW</a>
1600x800:	<a href="#">SSOLO/1600800CMW</a>
1800x800:	<a href="#">SSOLO/1800800CMW</a>



BLACK  
Silver Frame

1200x800:	<a href="#">SSOLO/1200800BLA</a>
1400x800:	<a href="#">SSOLO/1400800BLA</a>
1600x800:	<a href="#">SSOLO/1600800BLA</a>
1800x800:	<a href="#">SSOLO/1800800BLA</a>



GRAPHITE  
Silver Frame

1200x800:	<a href="#">SSOLO/1200800GRA</a>
1400x800:	<a href="#">SSOLO/1400800GRA</a>
1600x800:	<a href="#">SSOLO/1600800GRA</a>
1800x800:	<a href="#">SSOLO/1800800GRA</a>



TIMBER  
Silver Frame

1200x800:	<a href="#">SSOLO/1200800TIM</a>
1400x800:	<a href="#">SSOLO/1400800TIM</a>
1600x800:	<a href="#">SSOLO/1600800TIM</a>
1800x800:	<a href="#">SSOLO/1800800TIM</a>



## SOLO WHITE FRAMES



BEECH  
White Frame

1200x800: [WSOLO/1200800BEE](#)  
1400x800: [WSOLO/1400800BEE](#)  
1600x800: [WSOLO/1600800BEE](#)  
1800x800: [WSOLO/1800800BEE](#)



GREY NEBRASKA OAK  
White Frame

1200x800: [WSOLO/1200800GNO](#)  
1400x800: [WSOLO/1400800GNO](#)  
1600x800: [WSOLO/1600800GNO](#)  
1800x800: [WSOLO/1800800GNO](#)



GREY  
White Frame

1200x800: [WSOLO/1200800GRY](#)  
1400x800: [WSOLO/1400800GRY](#)  
1600x800: [WSOLO/1600800GRY](#)  
1800x800: [WSOLO/1800800GRY](#)



MAPLE  
White Frame

1200x800: [WSOLO/1200800MAP](#)  
1400x800: [WSOLO/1400800MAP](#)  
1600x800: [WSOLO/1600800MAP](#)  
1800x800: [WSOLO/1800800MAP](#)



OAK  
White Frame

1200x800: [WSOLO/1200800OAK](#)  
1400x800: [WSOLO/1400800OAK](#)  
1600x800: [WSOLO/1600800OAK](#)  
1800x800: [WSOLO/1800800OAK](#)



WALNUT  
White Frame

1200x800: [WSOLO/1200800WAL](#)  
1400x800: [WSOLO/1400800WAL](#)  
1600x800: [WSOLO/1600800WAL](#)  
1800x800: [WSOLO/1800800WAL](#)



WENGE  
White Frame

1200x800: [WSOLO/1200800WEN](#)  
1400x800: [WSOLO/1400800WEN](#)  
1600x800: [WSOLO/1600800WEN](#)  
1800x800: [WSOLO/1800800WEN](#)



WHITE  
White Frame

1200x800: [WSOLO/1200800WHI](#)  
1400x800: [WSOLO/1400800WHI](#)  
1600x800: [WSOLO/1600800WHI](#)  
1800x800: [WSOLO/1800800WHI](#)



CARBON MARINE WOOD  
White Frame

1200x800: [WSOLO/1200800CMW](#)  
1400x800: [WSOLO/1400800CMW](#)  
1600x800: [WSOLO/1600800CMW](#)  
1800x800: [WSOLO/1800800CMW](#)



BLACK  
White Frame

1200x800: [WSOLO/1200800BLA](#)  
1400x800: [WSOLO/1400800BLA](#)  
1600x800: [WSOLO/1600800BLA](#)  
1800x800: [WSOLO/1800800BLA](#)



GRAPHITE  
White Frame

1200x800: [WSOLO/1200800GRA](#)  
1400x800: [WSOLO/1400800GRA](#)  
1600x800: [WSOLO/1600800GRA](#)  
1800x800: [WSOLO/1800800GRA](#)



TIMBER  
White Frame

1200x800: [WSOLO/1200800TIM](#)  
1400x800: [WSOLO/1400800TIM](#)  
1600x800: [WSOLO/1600800TIM](#)  
1800x800: [WSOLO/1800800TIM](#)





## SOLO BLACK FRAMES



BEECH  
Black Frame

1200x800: [BSOLO/1200800BEE](#)  
 1400x800: [BSOLO/1400800BEE](#)  
 1600x800: [BSOLO/1600800BEE](#)  
 1800x800: [BSOLO/1800800BEE](#)



GREY NEBRASKA OAK  
Black Frame

1200x800: [BSOLO/1200800GNO](#)  
 1400x800: [BSOLO/1400800GNO](#)  
 1600x800: [BSOLO/1600800GNO](#)  
 1800x800: [BSOLO/1800800GNO](#)



GREY  
Black Frame

1200x800: [BSOLO/1200800GRY](#)  
 1400x800: [BSOLO/1400800GRY](#)  
 1600x800: [BSOLO/1600800GRY](#)  
 1800x800: [BSOLO/1800800GRY](#)



MAPLE  
Black Frame

1200x800: [BSOLO/1200800MAP](#)  
 1400x800: [BSOLO/1400800MAP](#)  
 1600x800: [BSOLO/1600800MAP](#)  
 1800x800: [BSOLO/1800800MAP](#)



OAK  
Black Frame

1200x800: [BSOLO/1200800OAK](#)  
 1400x800: [BSOLO/1400800OAK](#)  
 1600x800: [BSOLO/1600800OAK](#)  
 1800x800: [BSOLO/1800800OAK](#)



WALNUT  
Black Frame

1200x800: [BSOLO/1200800WAL](#)  
 1400x800: [BSOLO/1400800WAL](#)  
 1600x800: [BSOLO/1600800WAL](#)  
 1800x800: [BSOLO/1800800WAL](#)



WENGE  
Black Frame

1200x800: [BSOLO/1200800WEN](#)  
 1400x800: [BSOLO/1400800WEN](#)  
 1600x800: [BSOLO/1600800WEN](#)  
 1800x800: [BSOLO/1800800WEN](#)



WHITE  
Black Frame

1200x800: [BSOLO/1200800WHI](#)  
 1400x800: [BSOLO/1400800WHI](#)  
 1600x800: [BSOLO/1600800WHI](#)  
 1800x800: [BSOLO/1800800WHI](#)



CARBON MARINE WOOD  
Black Frame

1200x800: [BSOLO/1200800CMW](#)  
 1400x800: [BSOLO/1400800CMW](#)  
 1600x800: [BSOLO/1600800CMW](#)  
 1800x800: [BSOLO/1800800CMW](#)



BLACK  
Black Frame

1200x800: [BSOLO/1200800BLA](#)  
 1400x800: [BSOLO/1400800BLA](#)  
 1600x800: [BSOLO/1600800BLA](#)  
 1800x800: [BSOLO/1800800BLA](#)



GRAPHITE  
Black Frame

1200x800: [BSOLO/1200800GRA](#)  
 1400x800: [BSOLO/1400800GRA](#)  
 1600x800: [BSOLO/1600800GRA](#)  
 1800x800: [BSOLO/1800800GRA](#)



TIMBER  
Black Frame

1200x800: [BSOLO/1200800TIM](#)  
 1400x800: [BSOLO/1400800TIM](#)  
 1600x800: [BSOLO/1600800TIM](#)  
 1800x800: [BSOLO/1800800TIM](#)



# CROWN

## DUAL MOTOR

The Crown height adjustable desk is a high quality sturdy electric workstation powered by two Scandinavian motors. With its four-leg sleek design, the Crown merges design appeal and prestige with the ultimate ergonomic desk solution. It can also be used as a versatile meeting table.

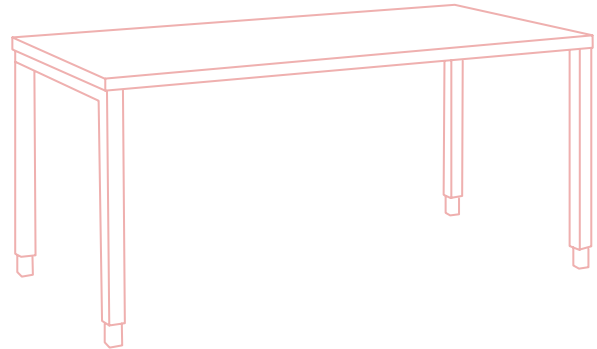

White  
RAL 9016



Silver  
RAL 9006



Black  
RAL 9005

> Dual Motor Desk

> Next Day Delivery

> 5 Year Guarantee

## PRODUCT DETAILS

Guarantee	Height Range (stroke)	Anti-Collision
<b>5yrs</b>	<b>680mm-1170mm</b>	<b>Yes</b>
Frame Width Adjustment	Voltage	Duty Cycle
<b>1300mm-1800mm</b>	<b>230V AC Input, 24V DC operation</b>	<b>10% - 2mins on, 18mins off</b>
Frame Depth	Speed	Noise Level
<b>795mm</b>	<b>40mm per second</b>	<b>&lt;42 dB</b>
Leg Profile	Standby Power	CE Compliance
<b>50mm</b>	<b>&lt;0.3 W</b>	<b>Machine Directive 2006/42/EC, EMC Directive 2014/30EU</b>
Load Capacity	Max Operational Power	
<b>120kg</b>	<b>300W</b>	
Frame Weight	Overload Protection	
<b>40kg</b>	<b>Yes</b>	
Life	Thermal Protection	
<b>10,000 cycles at full rated load</b>	<b>Yes</b>	

CROWN BLACK FRAME WITH  
1600X800MM WALNUT TOP



EXECUTIVE DESK SOLUTION



## CROWN SILVER FRAMES



BEECH  
Silver Frame

1400x800:	<a href="#">SCRO/1400800BEE</a>
1600x800:	<a href="#">SCRO/1600800BEE</a>
1800x800:	<a href="#">SCRO/1800800BEE</a>



GREY NEBRASKA OAK  
Silver Frame

1400x800:	<a href="#">SCRO/1400800GNO</a>
1600x800:	<a href="#">SCRO/1600800GNO</a>
1800x800:	<a href="#">SCRO/1800800GNO</a>



GREY  
Silver Frame

1400x800:	<a href="#">SCRO/1400800GRY</a>
1600x800:	<a href="#">SCRO/1600800GRY</a>
1800x800:	<a href="#">SCRO/1800800GRY</a>



MAPLE  
Silver Frame

1400x800:	<a href="#">SCRO/1400800MAP</a>
1600x800:	<a href="#">SCRO/1600800MAP</a>
1800x800:	<a href="#">SCRO/1800800MAP</a>



OAK  
Silver Frame

1400x800:	<a href="#">SCRO/1400800OAK</a>
1600x800:	<a href="#">SCRO/1600800OAK</a>
1800x800:	<a href="#">SCRO/1800800OAK</a>



WALNUT  
Silver Frame

1400x800:	<a href="#">SCRO/1400800WAL</a>
1600x800:	<a href="#">SCRO/1600800WAL</a>
1800x800:	<a href="#">SCRO/1800800WAL</a>



WENGE  
Silver Frame

1400x800:	<a href="#">SCRO/1400800WEN</a>
1600x800:	<a href="#">SCRO/1600800WEN</a>
1800x800:	<a href="#">SCRO/1800800WEN</a>



WHITE  
Silver Frame

1400x800:	<a href="#">SCRO/1400800WHI</a>
1600x800:	<a href="#">SCRO/1600800WHI</a>
1800x800:	<a href="#">SCRO/1800800WHI</a>



CARBON MARINE WOOD  
Silver Frame

1400x800:	<a href="#">SCRO/1400800CMW</a>
1600x800:	<a href="#">SCRO/1600800CMW</a>
1800x800:	<a href="#">SCRO/1800800CMW</a>



BLACK  
Silver Frame

1400x800:	<a href="#">SCRO/1400800BLA</a>
1600x800:	<a href="#">SCRO/1600800BLA</a>
1800x800:	<a href="#">SCRO/1800800BLA</a>



GRAPHITE  
Silver Frame

1400x800:	<a href="#">SCRO/1400800GRA</a>
1600x800:	<a href="#">SCRO/1600800GRA</a>
1800x800:	<a href="#">SCRO/1800800GRA</a>



TIMBER  
Silver Frame

1400x800:	<a href="#">SCRO/1400800TIM</a>
1600x800:	<a href="#">SCRO/1600800TIM</a>
1800x800:	<a href="#">SCRO/1800800TIM</a>



## CROWN WHITE FRAMES



BEECH  
White Frame

1400x800: [WCRO/1400800BEE](#)  
1600x800: [WCRO/1600800BEE](#)  
1800x800: [WCRO/1800800BEE](#)



GREY NEBRASKA OAK  
White Frame

1400x800: [WCRO/1400800GNO](#)  
1600x800: [WCRO/1600800GNO](#)  
1800x800: [WCRO/1800800GNO](#)



GREY  
White Frame

1400x800: [WCRO/1400800GRY](#)  
1600x800: [WCRO/1600800GRY](#)  
1800x800: [WCRO/1800800GRY](#)



MAPLE  
White Frame

1400x800: [WCRO/1400800MAP](#)  
1600x800: [WCRO/1600800MAP](#)  
1800x800: [WCRO/1800800MAP](#)



OAK  
White Frame

1400x800: [WCRO/1400800OAK](#)  
1600x800: [WCRO/1600800OAK](#)  
1800x800: [WCRO/1800800OAK](#)



WALNUT  
White Frame

1400x800: [WCRO/1400800WAL](#)  
1600x800: [WCRO/1600800WAL](#)  
1800x800: [WCRO/1800800WAL](#)



WENGE  
White Frame

1400x800: [WCRO/1400800WEN](#)  
1600x800: [WCRO/1600800WEN](#)  
1800x800: [WCRO/1800800WEN](#)



WHITE  
White Frame

1400x800: [WCRO/1400800WHI](#)  
1600x800: [WCRO/1600800WHI](#)  
1800x800: [WCRO/1800800WHI](#)



CARBON MARINE WOOD  
White Frame

1400x800: [WCRO/1400800CMW](#)  
1600x800: [WCRO/1600800CMW](#)  
1800x800: [WCRO/1800800CMW](#)



BLACK  
White Frame

1400x800: [WCRO/1400800BLA](#)  
1600x800: [WCRO/1600800BLA](#)  
1800x800: [WCRO/1800800BLA](#)



GRAPHITE  
White Frame

1400x800: [WCRO/1400800GRA](#)  
1600x800: [WCRO/1600800GRA](#)  
1800x800: [WCRO/1800800GRA](#)



TIMBER  
White Frame

1400x800: [WCRO/1400800TIM](#)  
1600x800: [WCRO/1600800TIM](#)  
1800x800: [WCRO/1800800TIM](#)



## CROWN BLACK FRAMES



BEECH  
Black Frame

1400x800: [BCRO/1400800BEE](#)  
1600x800: [BCRO/1600800BEE](#)  
1800x800: [BCRO/1800800BEE](#)



GREY NEBRASKA OAK  
Black Frame

1400x800: [BCRO/1400800GNO](#)  
1600x800: [BCRO/1600800GNO](#)  
1800x800: [BCRO/1800800GNO](#)



GREY  
Black Frame

1400x800: [BCRO/1400800GRY](#)  
1600x800: [BCRO/1600800GRY](#)  
1800x800: [BCRO/1800800GRY](#)



MAPLE  
Black Frame

1400x800: [BCRO/1400800MAP](#)  
1600x800: [BCRO/1600800MAP](#)  
1800x800: [BCRO/1800800MAP](#)



OAK  
Black Frame

1400x800: [BCRO/1400800OAK](#)  
1600x800: [BCRO/1600800OAK](#)  
1800x800: [BCRO/1800800OAK](#)



WALNUT  
Black Frame

1400x800: [BCRO/1400800WAL](#)  
1600x800: [BCRO/1600800WAL](#)  
1800x800: [BCRO/1800800WAL](#)



WENGE  
Black Frame

1400x800: [BCRO/1400800WEN](#)  
1600x800: [BCRO/1600800WEN](#)  
1800x800: [BCRO/1800800WEN](#)



WHITE  
Black Frame

1400x800: [BCRO/1400800WHI](#)  
1600x800: [BCRO/1600800WHI](#)  
1800x800: [BCRO/1800800WHI](#)



CARBON MARINE WOOD  
Black Frame

1400x800: [BCRO/1400800CMW](#)  
1600x800: [BCRO/1600800CMW](#)  
1800x800: [BCRO/1800800CMW](#)



BLACK  
Black Frame

1400x800: [BCRO/1400800BLA](#)  
1600x800: [BCRO/1600800BLA](#)  
1800x800: [BCRO/1800800BLA](#)



GRAPHITE  
Black Frame

1400x800: [BCRO/1400800GRA](#)  
1600x800: [BCRO/1600800GRA](#)  
1800x800: [BCRO/1800800GRA](#)



TIMBER  
Black Frame

1400x800: [BCRO/1400800TIM](#)  
1600x800: [BCRO/1600800TIM](#)  
1800x800: [BCRO/1800800TIM](#)





# DUO

## FOUR MOTORS

The Duo back-to-back workstation allows two users to independently raise and lower their workspace whilst being connected by a sleek single frame. The Duo can be used in conjunction with bench desking and screens to seamlessly fit the flow of any task environment. Compatible with the Advance memory control options and cable management system.

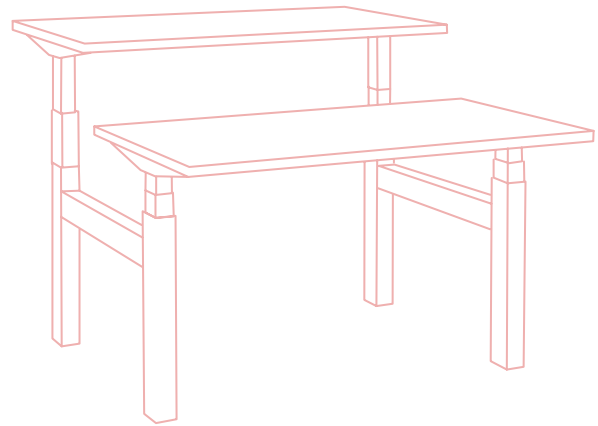

White  
RAL 9016



Silver  
RAL 9006



Black  
RAL 9005

> Four Motor Desk

> Next Day Delivery

> 5 Year Guarantee

## PRODUCT DETAILS

Guarantee

**5yrs**

Frame Width Adjustment

**1150mm-1740mm**

Side Supports (Brackets)

**540mm**

Leg Depth

**880mm**

Load Capacity

**120kg Each Work Station**

Frame Weight

**58kg**

Life

**10,000 cycles at full rated load**

Height Range (stroke)

**640mm-1300mm**

Voltage

**230V AC Input, 24V DC operation**

Speed

**40mm per second**

Standby Power

**<0.3 W**

Max Operational Power

**300W Each Work Station**

Overload Protection

**Yes**

Thermal Protection

**Yes**

Anti-Collision

**Yes**

Duty Cycle

**10% - 2mins on, 18mins off**

Noise Level

**<42 dB**

CE Compliance

**Machine Directive 2006/42/EC,  
EMC Directive 2014/30EU**

DUO BLACK FRAME WITH 1600X800MM  
GREY NESBRASKA OAK TOP



INDEPENDENT RAISING  
FUNCTIONALITY



## DUO SILVER FRAMES



BEECH  
Silver Frame

1200x800:	<a href="#">SDUO/1200800BEE</a>
1400x800:	<a href="#">SDUO/1400800BEE</a>
1600x800:	<a href="#">SDUO/1600800BEE</a>
1800x800:	<a href="#">SDUO/1800800BEE</a>

GREY NEBRASKA OAK  
Silver Frame

1200x800:	<a href="#">SDUO/1200800GNO</a>
1400x800:	<a href="#">SDUO/1400800GNO</a>
1600x800:	<a href="#">SDUO/1600800GNO</a>
1800x800:	<a href="#">SDUO/1800800GNO</a>

GREY  
Silver Frame

1200x800:	<a href="#">SDUO/1200800GRY</a>
1400x800:	<a href="#">SDUO/1400800GRY</a>
1600x800:	<a href="#">SDUO/1600800GRY</a>
1800x800:	<a href="#">SDUO/1800800GRY</a>

MAPLE  
Silver Frame

1200x800:	<a href="#">SDUO/1200800MAP</a>
1400x800:	<a href="#">SDUO/1400800MAP</a>
1600x800:	<a href="#">SDUO/1600800MAP</a>
1800x800:	<a href="#">SDUO/1800800MAP</a>



OAK  
Silver Frame

1200x800:	<a href="#">SDUO/1200800OAK</a>
1400x800:	<a href="#">SDUO/1400800OAK</a>
1600x800:	<a href="#">SDUO/1600800OAK</a>
1800x800:	<a href="#">SDUO/1800800OAK</a>

WALNUT  
Silver Frame

1200x800:	<a href="#">SDUO/1200800WAL</a>
1400x800:	<a href="#">SDUO/1400800WAL</a>
1600x800:	<a href="#">SDUO/1600800WAL</a>
1800x800:	<a href="#">SDUO/1800800WAL</a>

WENGE  
Silver Frame

1200x800:	<a href="#">SDUO/1200800WEN</a>
1400x800:	<a href="#">SDUO/1400800WEN</a>
1600x800:	<a href="#">SDUO/1600800WEN</a>
1800x800:	<a href="#">SDUO/1800800WEN</a>

WHITE  
Silver Frame

1200x800:	<a href="#">SDUO/1200800WHI</a>
1400x800:	<a href="#">SDUO/1400800WHI</a>
1600x800:	<a href="#">SDUO/1600800WHI</a>
1800x800:	<a href="#">SDUO/1800800WHI</a>



CARBON MARINE WOOD  
Silver Frame

1200x800:	<a href="#">SDUO/1200800CMW</a>
1400x800:	<a href="#">SDUO/1400800CMW</a>
1600x800:	<a href="#">SDUO/1600800CMW</a>
1800x800:	<a href="#">SDUO/1800800CMW</a>

BLACK  
Silver Frame

1200x800:	<a href="#">SDUO/1200800BLA</a>
1400x800:	<a href="#">SDUO/1400800BLA</a>
1600x800:	<a href="#">SDUO/1600800BLA</a>
1800x800:	<a href="#">SDUO/1800800BLA</a>

GRAPHITE  
Silver Frame

1200x800:	<a href="#">SDUO/1200800GRA</a>
1400x800:	<a href="#">SDUO/1400800GRA</a>
1600x800:	<a href="#">SDUO/1600800GRA</a>
1800x800:	<a href="#">SDUO/1800800GRA</a>

TIMBER  
Silver Frame

1200x800:	<a href="#">SDUO/1200800TIM</a>
1400x800:	<a href="#">SDUO/1400800TIM</a>
1600x800:	<a href="#">SDUO/1600800TIM</a>
1800x800:	<a href="#">SDUO/1800800TIM</a>



## DUO WHITE FRAMES



BEECH  
White Frame

1200x800: [WDUO/1200800BEE](#)  
1400x800: [WDUO/1400800BEE](#)  
1600x800: [WDUO/1600800BEE](#)  
1800x800: [WDUO/1800800BEE](#)



GREY NEBRASKA OAK  
White Frame

1200x800: [WDUO/1200800GNO](#)  
1400x800: [WDUO/1400800GNO](#)  
1600x800: [WDUO/1600800GNO](#)  
1800x800: [WDUO/1800800GNO](#)



GREY  
White Frame

1200x800: [WDUO/1200800GRY](#)  
1400x800: [WDUO/1400800GRY](#)  
1600x800: [WDUO/1600800GRY](#)  
1800x800: [WDUO/1800800GRY](#)



MAPLE  
White Frame

1200x800: [WDUO/1200800MAP](#)  
1400x800: [WDUO/1400800MAP](#)  
1600x800: [WDUO/1600800MAP](#)  
1800x800: [WDUO/1800800MAP](#)



OAK  
White Frame

1200x800: [WDUO/1200800OAK](#)  
1400x800: [WDUO/1400800OAK](#)  
1600x800: [WDUO/1600800OAK](#)  
1800x800: [WDUO/1800800OAK](#)



WALNUT  
White Frame

1200x800: [WDUO/1200800WAL](#)  
1400x800: [WDUO/1400800WAL](#)  
1600x800: [WDUO/1600800WAL](#)  
1800x800: [WDUO/1800800WAL](#)



WENGE  
White Frame

1200x800: [WDUO/1200800WEN](#)  
1400x800: [WDUO/1400800WEN](#)  
1600x800: [WDUO/1600800WEN](#)  
1800x800: [WDUO/1800800WEN](#)



WHITE  
White Frame

1200x800: [WDUO/1200800WHI](#)  
1400x800: [WDUO/1400800WHI](#)  
1600x800: [WDUO/1600800WHI](#)  
1800x800: [WDUO/1800800WHI](#)



CARBON MARINE WOOD  
White Frame

1200x800: [WDUO/1200800CMW](#)  
1400x800: [WDUO/1400800CMW](#)  
1600x800: [WDUO/1600800CMW](#)  
1800x800: [WDUO/1800800CMW](#)



BLACK  
White Frame

1200x800: [WDUO/1200800BLA](#)  
1400x800: [WDUO/1400800BLA](#)  
1600x800: [WDUO/1600800BLA](#)  
1800x800: [WDUO/1800800BLA](#)



GRAPHITE  
White Frame

1200x800: [WDUO/1200800GRA](#)  
1400x800: [WDUO/1400800GRA](#)  
1600x800: [WDUO/1600800GRA](#)  
1800x800: [WDUO/1800800GRA](#)



TIMBER  
White Frame

1200x800: [WDUO/1200800TIM](#)  
1400x800: [WDUO/1400800TIM](#)  
1600x800: [WDUO/1600800TIM](#)  
1800x800: [WDUO/1800800TIM](#)



## DUO BLACK FRAMES



BEECH  
Black Frame

1200x800:	<a href="#">BDUO/1200800BEE</a>
1400x800:	<a href="#">BDUO/1400800BEE</a>
1600x800:	<a href="#">BDUO/1600800BEE</a>
1800x800:	<a href="#">BDUO/1800800BEE</a>



GREY NEBRASKA OAK  
Black Frame

1200x800:	<a href="#">BDUO/1200800GNO</a>
1400x800:	<a href="#">BDUO/1400800GNO</a>
1600x800:	<a href="#">BDUO/1600800GNO</a>
1800x800:	<a href="#">BDUO/1800800GNO</a>



GREY  
Black Frame

1200x800:	<a href="#">BDUO/1200800GRY</a>
1400x800:	<a href="#">BDUO/1400800GRY</a>
1600x800:	<a href="#">BDUO/1600800GRY</a>
1800x800:	<a href="#">BDUO/1800800GRY</a>



MAPLE  
Black Frame

1200x800:	<a href="#">BDUO/1200800MAP</a>
1400x800:	<a href="#">BDUO/1400800MAP</a>
1600x800:	<a href="#">BDUO/1600800MAP</a>
1800x800:	<a href="#">BDUO/1800800MAP</a>



OAK  
Black Frame

1200x800:	<a href="#">BDUO/1200800OAK</a>
1400x800:	<a href="#">BDUO/1400800OAK</a>
1600x800:	<a href="#">BDUO/1600800OAK</a>
1800x800:	<a href="#">BDUO/1800800OAK</a>



WALNUT  
Black Frame

1200x800:	<a href="#">BDUO/1200800WAL</a>
1400x800:	<a href="#">BDUO/1400800WAL</a>
1600x800:	<a href="#">BDUO/1600800WAL</a>
1800x800:	<a href="#">BDUO/1800800WAL</a>



WENGE  
Black Frame

1200x800:	<a href="#">BDUO/1200800WEN</a>
1400x800:	<a href="#">BDUO/1400800WEN</a>
1600x800:	<a href="#">BDUO/1600800WEN</a>
1800x800:	<a href="#">BDUO/1800800WEN</a>



WHITE  
Black Frame

1200x800:	<a href="#">BDUO/1200800WHI</a>
1400x800:	<a href="#">BDUO/1400800WHI</a>
1600x800:	<a href="#">BDUO/1600800WHI</a>
1800x800:	<a href="#">BDUO/1800800WHI</a>



CARBON MARINE WOOD  
Black Frame

1200x800:	<a href="#">BDUO/1200800CMW</a>
1400x800:	<a href="#">BDUO/1400800CMW</a>
1600x800:	<a href="#">BDUO/1600800CMW</a>
1800x800:	<a href="#">BDUO/1800800CMW</a>



BLACK  
Black Frame

1200x800:	<a href="#">BDUO/1200800BLA</a>
1400x800:	<a href="#">BDUO/1400800BLA</a>
1600x800:	<a href="#">BDUO/1600800BLA</a>
1800x800:	<a href="#">BDUO/1800800BLA</a>



GRAPHITE  
Black Frame

1200x800:	<a href="#">BDUO/1200800GRA</a>
1400x800:	<a href="#">BDUO/1400800GRA</a>
1600x800:	<a href="#">BDUO/1600800GRA</a>
1800x800:	<a href="#">BDUO/1800800GRA</a>



TIMBER  
Black Frame

1200x800:	<a href="#">BDUO/1200800TIM</a>
1400x800:	<a href="#">BDUO/1400800TIM</a>
1600x800:	<a href="#">BDUO/1600800TIM</a>
1800x800:	<a href="#">BDUO/1800800TIM</a>



FOR SCREEN OPTIONS PLEASE  
SEE ACCESSORY SECTION



FOR LOWER CABLE  
TRAYS PLEASE SEE  
ACCESSORY SECTION



# ADVANCE MEETING TABLE D END

The Advance electric height adjustable meeting table is a sturdy dual motor system with anti-collision functionality. Ideal for smaller boardrooms and collaborative areas where standing up for meetings provides a lively and energetic cadence. It also will lower to 640mm, catering for wheelchair users and broadens the potential of use in any environment.

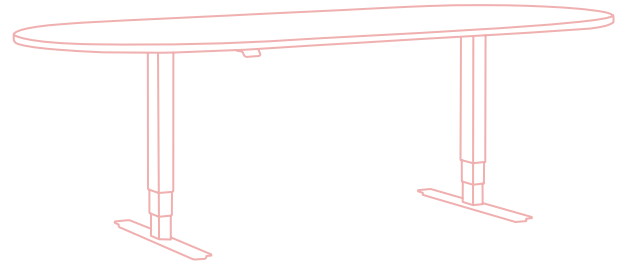

White  
RAL 9016



Silver  
RAL 9006



Black  
RAL 9005

> Dual Motor Table

> Next Day Delivery

> 5 Year Guarantee

## PRODUCT DETAILS

Guarantee

**5yrs**

Frame Widths

**1150mm - 1740mm**

Side Supports

**540mm**

Leg Size

**690mm**

Load Capacity

**120kg**

Frame Weight

**32kg**

Life

**10,000 cycles at full rated load**

Height Range

**640mm-1300mm**

Voltage

**230V AC Input, 24V DC operation**

Speed

**40mm per second**

Standby Power

**<0.3 W**

Max Operational Power

**300W**

Overload Protection

**Yes**

Thermal Protection

**Yes**

Anti-Collision

**Yes**

Duty Cycle

**10% - 2mins on, 18mins off**

Noise Level

**<42 dB**

CE Compliance

**Machine Directive 2006/42/EC,**

**EMC Directive 2014/30EU**

ADVANCE MEETING TABLE BLACK  
FRAME AND 2000X1000MM D END  
WALNUT TOP



HIGH QUALITY DUAL  
MOTOR SYSTEM

# SILVER



BEECH  
Silver Frame

2400x1000: [SADVM/D24001000BEE](#)



OAK  
Silver Frame

2400x1000: [SADVM/D24001000OAK](#)



WALNUT  
Silver Frame

2400x1000: [SADVM/D24001000WAL](#)



WHITE  
Silver Frame

2400x1000: [SADVM/D24001000WHI](#)



MAPLE  
Silver Frame

2400x1000: [SADVM/D24001000MAP](#)

---

# WHITE



BEECH  
White Frame

2400x1000: [WADVM/D24001000BEE](#)



OAK  
White Frame

2400x1000: [WADVM/D24001000OAK](#)



WALNUT  
White Frame

2400x1000: [WADVM/D24001000WAL](#)



WHITE  
White Frame

2400x1000: [WADVM/D24001000WHI](#)



MAPLE  
White Frame

2400x1000: [WADVM/D24001000MAP](#)

# BLACK



BEECH  
Black Frame

2400x1000: [BADVM/D24001000BEE](#)



OAK  
Black Frame

2400x1000: [BADVM/D24001000OAK](#)



WALNUT  
Black Frame

2400x1000: [BADVM/D24001000WAL](#)



WHITE  
Black Frame

2400x1000: [BADVM/D24001000WHI](#)



MAPLE  
Black Frame

2400x1000: [BADVM/D24001000MAP](#)



# ADVANCE MEETING TABLE BARREL STYLE

The Advance electric height adjustable meeting table is a sturdy dual motor system with anti-collision functionality. Ideal for smaller boardrooms and collaborative areas where standing up for meetings provides a lively and energetic cadence. It also will lower to 640mm, catering for wheelchair users and broadens the potential of use in any environment.

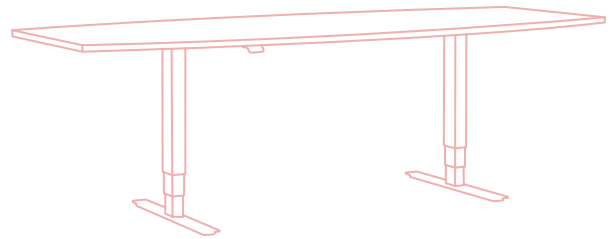

White  
RAL 9016



Silver  
RAL 9006



Black  
RAL 9005

> Dual Motor Table

> Next Day Delivery

> 5 Year Guarantee

## PRODUCT DETAILS

Guarantee	Height Range	Anti-Collision
<b>5yrs</b>	<b>640mm-1300mm</b>	<b>Yes</b>
Frame Widths	Voltage	Duty Cycle
<b>1150mm - 1740mm</b>	<b>230V AC Input, 24V DC operation</b>	<b>10% - 2mins on, 18mins off</b>
Side Supports	Speed	Noise Level
<b>540mm</b>	<b>40mm per second</b>	<b>&lt;42 dB</b>
Leg Size	Standby Power	CE Compliance
<b>690mm</b>	<b>&lt;0.3 W</b>	<b>Machine Directive 2006/42/EC, EMC Directive 2014/30EU</b>
Load Capacity	Max Operational Power	
<b>120kg</b>	<b>300W</b>	
Frame Weight	Overload Protection	
<b>32kg</b>	<b>Yes</b>	
Life	Thermal Protection	
<b>10,000 cycles at full rated load</b>	<b>Yes</b>	

ADVANCE MEETING TABLE BLACK  
FRAME WITH 2000X1000MM  
BARREL MAPLE TOP



HIGH QUALITY DUAL  
MOTOR SYSTEM

# SILVER



BEECH  
Silver Frame

2400x1000: [SADVM/B24001000BEE](#)



OAK  
Silver Frame

2400x1000: [SADVM/B24001000OAK](#)



WALNUT  
Silver Frame

2400x1000: [SADVM/B24001000WAL](#)



WHITE  
Silver Frame

2400x1000: [SADVM/B24001000WHI](#)



MAPLE  
Silver Frame

2400x1000: [SADVM/B24001000MAP](#)

---

# WHITE



BEECH  
White Frame

2400x1000: [WADVMB24001000BEE](#)



OAK  
White Frame

2400x1000: [WADVMB24001000OAK](#)



WALNUT  
White Frame

2400x1000: [WADVMB24001000WAL](#)



WHITE  
White Frame

2400x1000: [WADVMB24001000WHI](#)



MAPLE  
White Frame

2400x1000: [WADVMB24001000MAP](#)



# BLACK



BEECH  
Black Frame

2400x1000: [BADVM/B24001000BEE](#)



OAK  
Black Frame

2400x1000: [BADVM/B24001000OAK](#)



WALNUT  
Black Frame

2400x1000: [BADVM/B24001000WAL](#)



WHITE  
Black Frame

2400x1000: [BADVM/B24001000WHI](#)



MAPLE  
Black Frame

2400x1000: [BADVM/B24001000MAP](#)



# TEAM

## TRIPLE MOTOR

The Team meeting and conference table is a versatile triple motor frame system that adjusts easily to allow tables tops of anywhere between 2.4m and 4m in length! With its timeless Scandinavian design and concealed motors, the Team table will subtly transform any meeting facility!

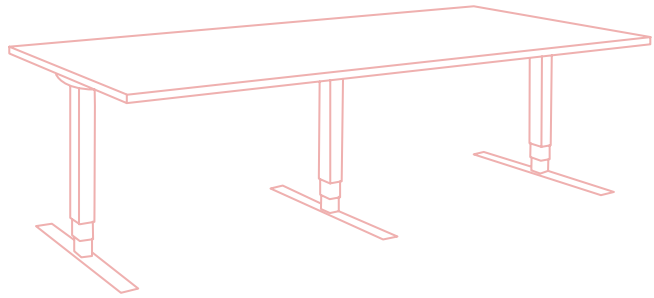

White  
RAL 9016



Silver  
RAL 9006



Black  
RAL 9005

> Triple Motor Table

> Next Day Delivery

> 5 Year Guarantee

## PRODUCT DETAILS

Guarantee

**5yrs**

Frame Width Adjustment

**2350mm-3530mm**

Side Supports (Brackets)

**740mm**

Leg Depth

**890mm**

Load Capacity

**160kg**

Frame Weight

**55kg**

Life

**10,000 cycles at full rated load**

Height Range (stroke)

**640mm-1300mm**

Voltage

**230V AC Input, 24V DC operation**

Speed

**40mm per second**

Standby Power

**<0.3 W**

Max Operational Power

**410W**

Overload Protection

**Yes**

Thermal Protection

**Yes**

Anti-Collision

**Yes**

Duty Cycle

**10% - 2mins on, 18mins off**

Noise Level

**<42 dB**

CE Compliance

**Machine Directive 2006/42/EC,**

**EMC Directive 2014/30EU**

TEAM WHITE FRAME WITH  
2400X1200MM WALNUT TOP



PERFECT FOR TABLE  
TOPS BETWEEN 2.4M  
AND 4M IN LENGTH

# TEAM

## FRAME OPTIONS

The Team frame features a telescopic beam system, enabling it to take a huge range of top dimensions.

### BASE

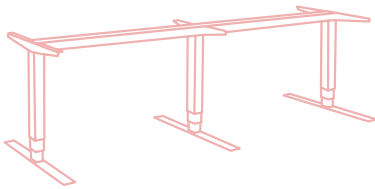

Frame Minimum Width - 2350mm  
Frame Maximum Width - 3530mm

### TOPS



Top Minimum Width - 2400mm  
Top Maximum Width - 5000mm  
Top Minimum Depth - 700mm  
Top Maximum Depth - 1500mm

WE MANUFACTURE TOPS TO  
YOUR EXACT SPECIFICATION

To facilitate any requirement. To view more information  
on our bespoke top options, check out page 86-87





TEAM

Silver Frame

STEA



TEAM

White Frame

WTEA



TEAM

Black Frame

BTEA

# COLLABORATE

## FOUR MOTOR

The Collaborate height adjustable table is a unique system featuring four Linak® heavy duty concealed motors with soft-touch operation. This prestigious designer meeting and conference table gives an opportunity for endless applications, from board meetings to events.

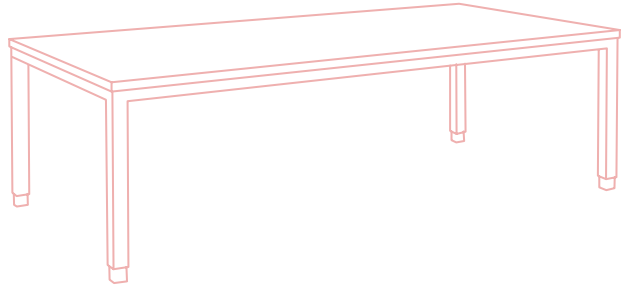

White  
RAL 9016



Silver  
RAL 9006

> Four Motor Table

> Next Day Delivery

> 5 Year Guarantee

## PRODUCT DETAILS

Guarantee

**5yrs**

Frame Width Adjustment

**N/A**

Frame Depth

**1200mm**

Leg Profile

**50mm**

Load Capacity

**160kg**

Frame Weight

**49kg**

Life

**10,000 cycles at full rated load**

Height Range (stroke)

**680mm-1180mm**

Voltage

**230V AC Input, 24V DC operation**

Speed

**40mm per second**

Standby Power

**<0.3 W**

Max Operational Power

**600W**

Overload Protection

**Yes**

Thermal Protection

**Yes**

Anti-Collision

**Yes**

Duty Cycle

**10% - 2mins on, 18mins off**

Noise Level

**<42 dB**

CE Compliance

**Machine Directive 2006/42/EC,**

**EMC Directive 2014/30EU**

COLLABORATE WHITE FRAME  
WITH 2400X1200MM GREY  
NEBRASKA OAK TOP

HEAVY DUTY CONCEALED  
MOTORS WITH SOFT  
TOUCH OPERATION



# COLLABORATE

## FRAME OPTIONS

Create the exact look you want by choosing from any Egger/Kronospan finish and bring your workspace to life.

### BASE

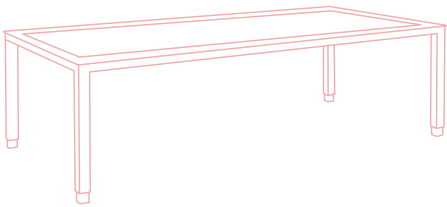

Frame Width - 1200mm  
Frame Depth - 2400mm

### TOPS



Top Minimum Width - 2400mm  
Top Minimum Depth - 1200mm

## WE MANUFACTURE TOPS TO YOUR EXACT SPECIFICATION

To facilitate any requirement. To view more information  
on our bespoke top options, check out pages 86-87

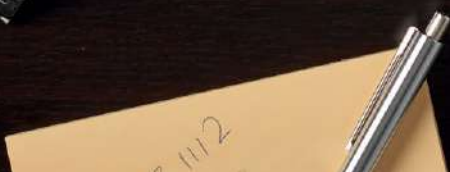



COLLABORATE

Silver Frame

SCOL

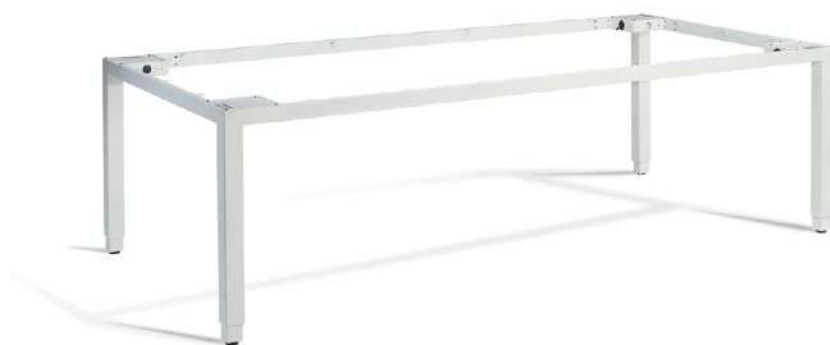

COLLABORATE

White Frame

WCOL

# FORGE

## DUAL MOTOR

One of the most heavy duty desks on the market, with a vintage industrial effect finish. These desks feature all welds and burnishes created in the production process, but finished with a smooth clear lacquer for the ultimate industrial look without compromising its ultra smooth operation. The Forge has a dual motor operation and has an extendable central beam system to facilitate all top sizes between 1200-1800mm.

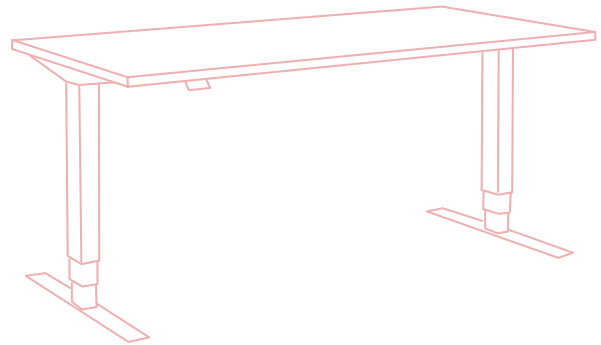

> Dual Motor Desk

> Next Day Delivery

> 5 Year Guarantee

## PRODUCT DETAILS

Guarantee	Height Range (stroke)	Anti-Collision
<b>5yrs</b>	<b>640mm-1300mm</b>	<b>Yes</b>
Frame Width Adjustment	Voltage	Duty Cycle
<b>1150mm-1740mm</b>	<b>230V AC Input, 24V DC operation</b>	<b>10% - 2mins on, 18mins off</b>
Side Supports (Brackets)	Speed	Noise Level
<b>540mm</b>	<b>40mm per second</b>	<b>&lt;42 dB</b>
Leg Depth	Standby Power	CE Compliance
<b>690mm</b>	<b>&lt;0.3 W</b>	<b>Machine Directive 2006/42/EC,</b>
Load Capacity	Max Operational Power	<b>EMC Directive 2014/30EU</b>
<b>120kg</b>	<b>300W</b>	
Frame Weight	Overload Protection	
<b>29kg</b>	<b>Yes</b>	
Life	Thermal Protection	
<b>10,000 cycles at full rated load</b>	<b>Yes</b>	

FORGE FRAME WITH  
1600X800MM TIMBER TOP



VINTAGE INDUSTRIAL NATURAL  
LACQUERED STEEL FINISH



## FORGE RAW FRAMES



BEECH  
Raw Frame

1200x800:	<a href="#">FORS/1200800BEE</a>
1400x800:	<a href="#">FORS/1400800BEE</a>
1600x800:	<a href="#">FORS/1600800BEE</a>
1800x800:	<a href="#">FORS/1800800BEE</a>



GREY NEBRASKA OAK  
Raw Frame

1200x800:	<a href="#">FORS/1200800GNO</a>
1400x800:	<a href="#">FORS/1400800GNO</a>
1600x800:	<a href="#">FORS/1600800GNO</a>
1800x800:	<a href="#">FORS/1800800GNO</a>



GREY  
Raw Frame

1200x800:	<a href="#">FORS/1200800GRY</a>
1400x800:	<a href="#">FORS/1400800GRY</a>
1600x800:	<a href="#">FORS/1600800GRY</a>
1800x800:	<a href="#">FORS/1800800GRY</a>



MAPLE  
Raw Frame

1200x800:	<a href="#">FORS/1200800MAP</a>
1400x800:	<a href="#">FORS/1400800MAP</a>
1600x800:	<a href="#">FORS/1600800MAP</a>
1800x800:	<a href="#">FORS/1800800MAP</a>



OAK  
Raw Frame

1200x800:	<a href="#">FORS/1200800OAK</a>
1400x800:	<a href="#">FORS/1400800OAK</a>
1600x800:	<a href="#">FORS/1600800OAK</a>
1800x800:	<a href="#">FORS/1800800OAK</a>



WALNUT  
Raw Frame

1200x800:	<a href="#">FORS/1200800WAL</a>
1400x800:	<a href="#">FORS/1400800WAL</a>
1600x800:	<a href="#">FORS/1600800WAL</a>
1800x800:	<a href="#">FORS/1800800WAL</a>



WENGE  
Raw Frame

1200x800:	<a href="#">FORS/1200800WEN</a>
1400x800:	<a href="#">FORS/1400800WEN</a>
1600x800:	<a href="#">FORS/1600800WEN</a>
1800x800:	<a href="#">FORS/1800800WEN</a>



WHITE  
Raw Frame

1200x800:	<a href="#">FORS/1200800WHI</a>
1400x800:	<a href="#">FORS/1400800WHI</a>
1600x800:	<a href="#">FORS/1600800WHI</a>
1800x800:	<a href="#">FORS/1800800WHI</a>



CARBON MARINE WOOD  
Raw Frame

1200x800:	<a href="#">FORS/1200800OAK</a>
1400x800:	<a href="#">FORS/1400800OAK</a>
1600x800:	<a href="#">FORS/1600800OAK</a>
1800x800:	<a href="#">FORS/1800800OAK</a>



BLACK  
Raw Frame

1200x800:	<a href="#">FORS/1200800BLA</a>
1400x800:	<a href="#">FORS/1400800BLA</a>
1600x800:	<a href="#">FORS/1600800BLA</a>
1800x800:	<a href="#">FORS/1800800BLA</a>



GRAPHITE  
Raw Frame

1200x800:	<a href="#">FORS/1200800GRA</a>
1400x800:	<a href="#">FORS/1400800GRA</a>
1600x800:	<a href="#">FORS/1600800GRA</a>
1800x800:	<a href="#">FORS/1800800GRA</a>



TIMBER  
Raw Frame

1200x800:	<a href="#">FORS/1200800TIM</a>
1400x800:	<a href="#">FORS/1400800TIM</a>
1600x800:	<a href="#">FORS/1600800TIM</a>
1800x800:	<a href="#">FORS/1800800TIM</a>



# FORGE CORNER

## TRIPLE MOTOR

A triple motor right angled version of the Forge desk – a heavy duty vintage industrial finished frame. As with the standard Forge desk, the Forge Corner features visible weld spots and burnishes created in the production process, but finished with a smooth clear lacquer for the ultimate industrial look without compromising its ultra-smooth operation.

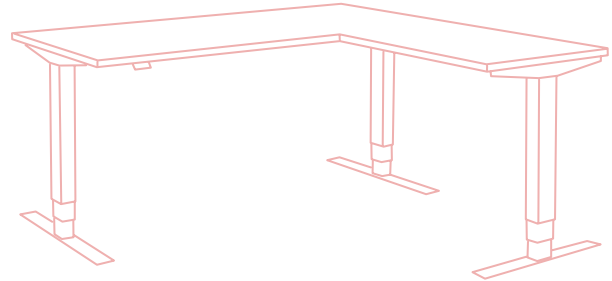

> Triple Motor Desk

> Next Day Delivery

> 5 Year Guarantee

## PRODUCT DETAILS

Guarantee

**5yrs**

Frame Width Adjustment

**1150-1740mm x 1545-2135mm**

Side Supports (Brackets)

**540mm**

Leg Size

**540mm x 2, 490mm x1**

Load Capacity

**160kg**

Frame Weight

**48kg**

Life

**10,000 cycles at full rated load**

Height Range (stroke)

**640mm-1300mm**

Voltage

**230V AC Input, 24V DC operation**

Speed

**40mm per second**

Standby Power

**<0.3 W**

Max Operational Power

**410W**

Overload Protection

**Yes**

Thermal Protection

**Yes**

Anti-Collision

**Yes**

Duty Cycle

**10% - 2mins on, 18mins off**

Noise Level

**<42 dB**

CE Compliance

**Machine Directive 2006/42/EC,**

**EMC Directive 2014/30EU**

FORGE CORNER FRAME WITH  
1600X1600 TIMBER TOP



VINTAGE INDUSTRIAL NATURAL  
LACQUERED STEEL FINISH





# FORGE CORNER RAW FRAMES



BEECH  
Raw Frame

1600x1600: [FORC/16001600BEE](#)  
1800x1600: [FORC/18001600BEE](#)



GREY NEBRASKA OAK  
Raw Frame

1600x1600: [FORC/16001600GNO](#)  
1800x1600: [FORC/18001600GNO](#)



GREY  
Raw Frame

1600x1600: [FORC/16001600GRY](#)  
1800x1600: [FORC/18001600GRY](#)



MAPLE  
Raw Frame

1600x1600: [FORC/16001600MAP](#)  
1800x1600: [FORC/18001600MAP](#)



OAK  
Raw Frame

1600x1600: [FORC/16001600OAK](#)  
1800x1600: [FORC/18001600OAK](#)



WALNUT  
Raw Frame

1600x1600: [FORC/16001600WAL](#)  
1800x1600: [FORC/18001600WAL](#)



WENGE  
Raw Frame

1600x1600: [FORC/16001600WEN](#)  
1800x1600: [FORC/18001600WEN](#)



WHITE  
Raw Frame

1600x1600: [FORC/16001600WHI](#)  
1800x1600: [FORC/18001600WHI](#)



CARBON MARINE WOOD  
Raw Frame

1600x1600: [FORC/16001600OAK](#)  
1800x1600: [FORC/18001600OAK](#)



BLACK  
Raw Frame

1600x1600: [FORC/16001600BLA](#)  
1800x1600: [FORC/18001600BLA](#)



GRAPHITE  
Raw Frame

1600x1600: [FORC/16001600GRA](#)  
1800x1600: [FORC/18001600GRA](#)



TIMBER  
Raw Frame

1600x1600: [FORC/16001600TIM](#)  
1800x1600: [FORC/18001600TIM](#)



# BOOST

## GAS LIFT - SINGLE LEG TABLE

The Boost range is a highly flexible multi-use solution with a huge number of applications. Using silent but powerful gas lift mechanisms, this table will change the dynamics of any office, breakout area or eating area in seconds.

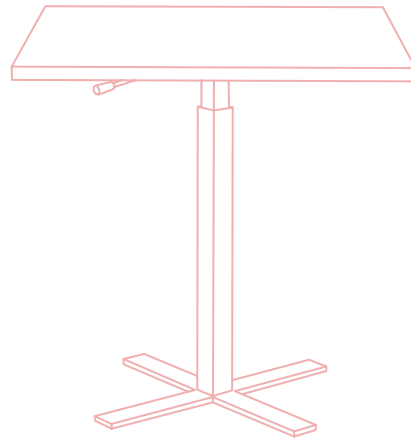

White  
RAL 9016



Silver  
RAL 9006



Black  
RAL 9005

> Gas Lift

> Next Day Delivery

> 5 Year Guarantee

## PRODUCT DETAILS (STANDARD)

Guarantee

**5yrs**

Frame Width Adjustment

**540mm**

Max Top Size

**550-700mm**

Leg Depth

**540mm**

Load Capacity

**N/A**

Frame Weight

**11kg**

Life Cycle

**N/A**

Height Range (stroke)

**600mm-1050mm**

## PRODUCT DETAILS (RECTANGLE)

Guarantee

**5yrs**

Frame Width Adjustment

**730mm**

Max Top Size

**600x900mm**

Leg Depth

**635mm**

Load Capacity

**N/A**

Frame Weight

**13kg**

Life Cycle

**N/A**

Height Range (stroke)

**600mm-1050mm**

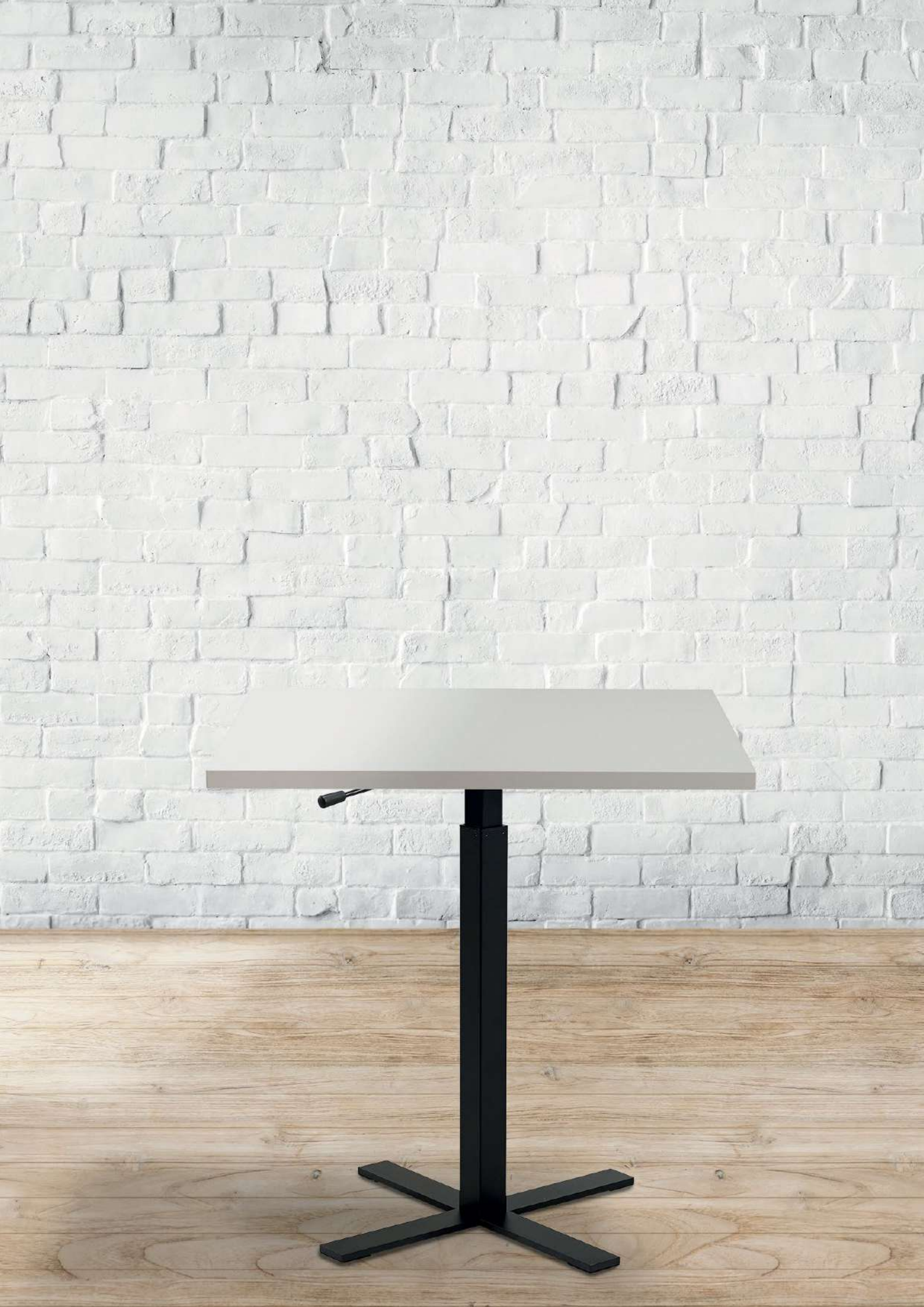



BOOST - FOR ROUND AND SQUARE TOPS UP TO 700X700MM OR 700MM DIAMETER



---

Boost Standard - Black

---

BBOOS



---

Boost Standard - Silver

---

SBOOS



---

Boost Standard - White

---

WBOOS

---

BOOST - FOR RECTANGULAR TOPS UP TO 900 X 600MM



---

Boost Rectangular - Black

---

BBOOR



---

Boost Rectangular - Silver

---

SBOOR



---

Boost Rectangular - White

---

WBOOR

AVAILABLE IN

Finish	700mm Diameter Round	700 x 700mm Square	600 x 900mm Rectangle
WHITE	700DWHI	700700WHI	900600WHI
GREY	700DGRY	700700GRY	900600GRY
OAK	700DOAK	700700OAK	900600OAK
BEECH	700DBEE	700700BEE	900600BEE
MAPLE	700DMAP	700700MAP	900600MAP
GREY NEBRASKA OAK	700DGNO	700700GNO	900600GNO
CARBON MARINE WOOD	700DCMW	700700CMW	900600CMW
BRAMBERG PINE	700DBRA	700700BRA	900600BRA
WALNUT	700DWAL	700700WAL	900600WAL
BLACK	700DBLA	700700BLA	900600BLA
WENGE	700DWEN	700700WEN	900600WEN
GRAPHITE	700DGRA	700700GRA	900600GRA



# FLEX

## SINGLE MOTOR

Flex - the most flexible and versatile height adjustable product on the market. These desks can be used as single user small workstations, lecterns, over-bed tables, television tables and much more. Featuring an incredible 660mm height range, the flex is suitable for every age and ability, being able to change with the environment or the needs of the user. Available with subtle integrated rear wheels, or with 4 heavy duty castors.

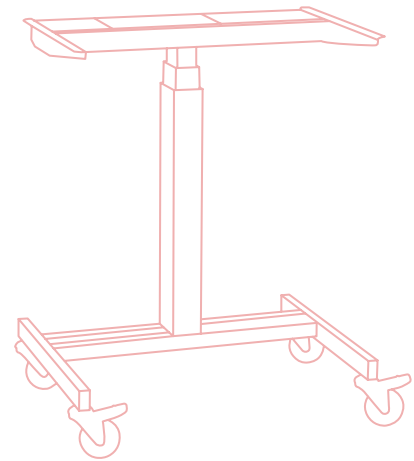

White  
RAL 9016



Silver  
RAL 9006



Black  
RAL 9005

> Single Motor Desk

> Next Day Delivery

> 5 Year Guarantee

## PRODUCT DETAILS

Guarantee

**5yrs**

Frame Width Adjustment

**590mm**

Max Top Size

**800x600mm**

Leg Depth

**590mm**

Load Capacity

**60kg**

Frame Weight

**21kg (Flex 2) 19kg (Flex 4)**

Life

**10,000 cycles at full rated load**

Height Range (stroke)

**615mm-1275mm (Flex 2)**

**715mm-1365mm (Flex 4)**

Voltage

**230V AC Input, 24V DC operation**

Speed

**40mm per second**

Standby Power

**<0.3 W**

Max Operational Power

**300W**

Overload Protection

**Yes**

Thermal Protection

**Yes**

Anti-Collision

**Yes**

Duty Cycle

**10% - 1min on, 9mins off**

Noise Level

**<42 dB**

CE Compliance

**Machine Directive 2006/42/EC,  
EMC Directive 2014/30EU**





FLEX WITH INTEGRATED REAR WHEELS



Flex 2 Wheel - Silver

SFLX2



Flex 2 Wheel - White

WFLX2



Flex 2 Wheel - Black

BFLX2

FLEX WITH 4 CASTORS



Flex 4 Wheel - Silver

SFLX4



Flex 4 Wheel - White

WFLX4



Flex 4 Wheel - Black

BFLX4

AVAILABLE IN

## Finish

800x600mm

WHITE

800600WHI

GREY

800600GRY

OAK

800600OAK

BEECH

800600BEE

MAPLE

800600MAP

GREY NEBRASKA OAK

800600GNO

CARBON MARINE WOOD

800600CMW

BRAMBERG PINE

800600BRA

WALNUT

800600WAL

BLACK

800600BLA

WENGE

800600WEN

GRAPHITE

800600GRA



# VAULT

## UNDER DESK DRAWER

The Vault is the ultimate compliment to an agile office. A lockable under-desk storage solution, perfect to keep phones, wallets and tablets. The Vault works with all of our desk ranges, and is available separately to use on any existing furniture.

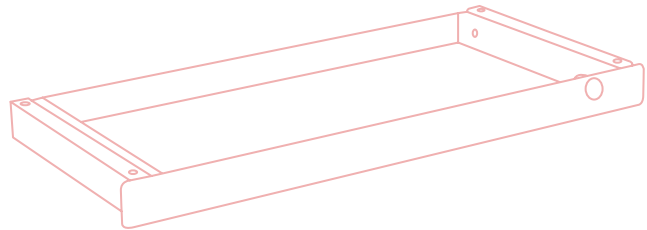

White  
RAL 9016



Silver  
RAL 9006



Black  
RAL 9005

> Under Desk Storage

> Next Day Delivery

> 5 Year Guarantee

## PRODUCT DETAILS

Guarantee

**5yrs**

Depth

**250mm**

Height

**44mm**

Width

**500mm**

Weight

**2kg**

Colour Options

**White, Silver, Black**

Lockable

**Yes**

Compatibility

**All Desks**

Material

**DC01 Epoxy Powder Coated Steel**

CONCEALED BALL BEARING  
SMOOTH GLIDE SYSTEM

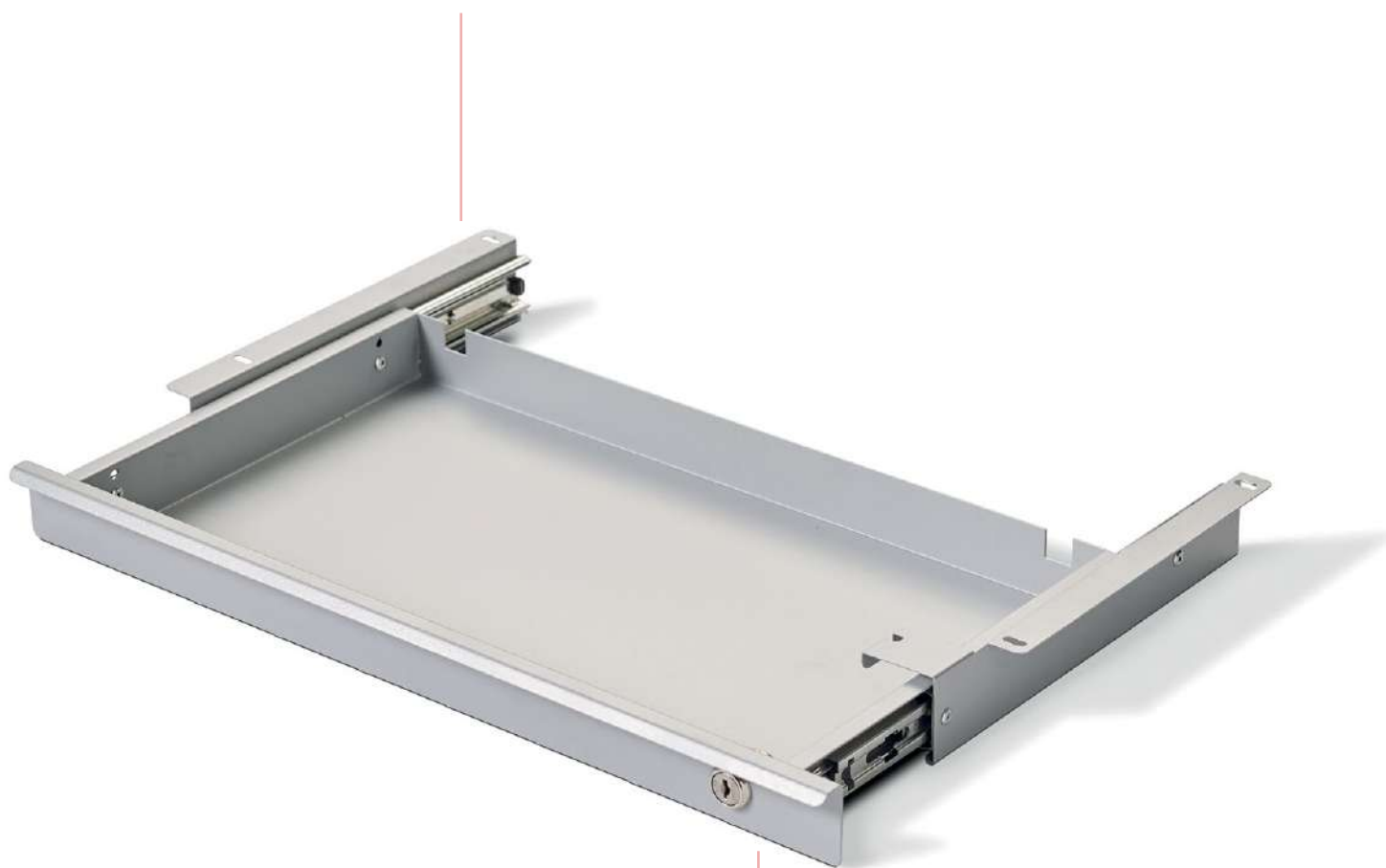

SECURE LOCKABLE STORAGE  
WITH 2 KEYS







VAULT

Silver

VAU500/SIL



VAULT

White

VAU500/WHI



VAULT

Black

VAU500/BLA



# FORM

## UNDER DESK DRAWER

Made in Italy to the highest possible specification, the Form pedestal range will fit seamlessly into all desking ranges. These pedestals all have soft-close drawers and ball bearing runner systems to ensure smooth, effortless operation and an unbeatable user experience. Comes with an internal stationery tray.

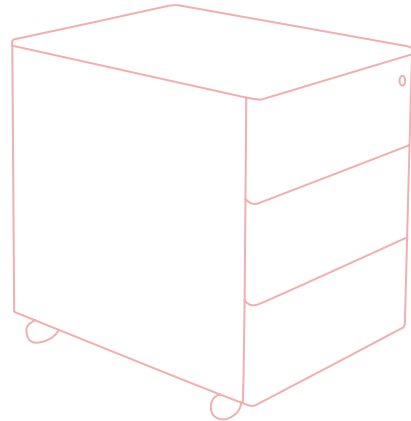

White  
RAL 9016



Silver  
RAL 9006



Black  
RAL 9005

> Made in Italy

> Next Day Delivery

> 5 Year Guarantee

"Designed to fit all height adjustable desks at their lowest setting."

## PRODUCT DETAILS

Guarantee	Width	Lockable
<b>5yrs</b>	<b>422mm</b>	<b>Yes</b>
Depth	Weight	Compatibility
<b>542mm</b>	<b>23kg (3 Drawer) 21.5kg (2 Drawer)</b>	<b>All Desks</b>
Height	Colour Options	Material
<b>535mm</b>	<b>White, Silver, Black</b>	<b>DC01 Epoxy Powder Coated Steel</b>

UNIQUELY DESIGNED TO ACCOMMODATE  
VARIABLE HEIGHT DESKING



SOFT CLOSE BALL BEARING RUNNERS  
FOR SILENT, SMOOTH OPERATION





---

Form - 2 Drawer

---

Silver

2FRM/SIL



---

Form - 2 Drawer

---

White

2FRM/WHI



---

Form - 2 Drawer

---

Black

2FRM/BLA



---

Form - 3 Drawer

---

Silver

3FRM/SIL



---

Form - 3 Drawer

---

White

3FRM/WHI



---

Form - 3 Drawer

---

Black

3FRM/BLA

# AVAILABLE STOCK TOPS

White  
KRONOSPAN K101



Grey  
KRONOSPAN U112



Maple  
KRONOSPAN D375



Grey Nebraska Oak  
EGGER H3332



Walnut  
EGGER H3704



Graphite  
KRONOSPAN 0162



## NEED A DIFFERENT SIZE OR DECOR?

We also offer a bespoke manufacturing service...

See next page for further details



Oak

EGGER H1334

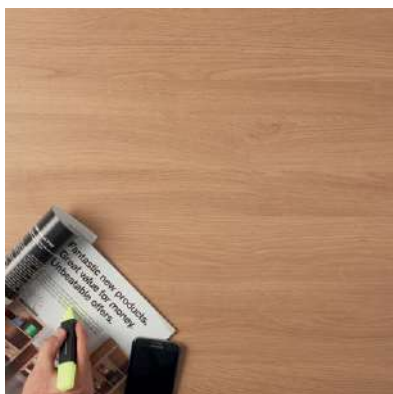

Beech

KRONOSPAN D381

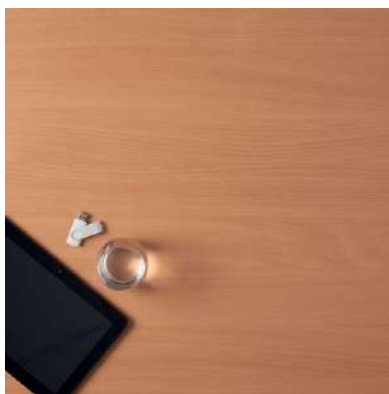

Timber

EGGER H1487



Carbon Marine Wood

KRONOSPAN K016



Black

EGGER U999



Wenge

EGGER H1137



## AVAILABLE STOCK SIZES

## RECTANGULAR

1200 x 700

1400 x 700

1600 x 700

1200 x 800

1400 x 800

1600 x 800

1800 x 800

600 x 900

600 x 800

## SQUARE

1200 x 700

## ROUND

1200 x 700





# BESPOKE TOPS

With in-house leading CNC machinery and design technology, we are able to manufacture tops in any size and finish to suit all customer requirements. For inspiration, Lavoro recommend that customers visit the websites of our primary décor partners.



[www.egger.com](http://www.egger.com)



[www.kronospan-express.com](http://www.kronospan-express.com)

---

For samples of any finish or to obtain a quotation on any bespoke option, contact our specialists on **0330 133 1112**.





## ACCESSORIES

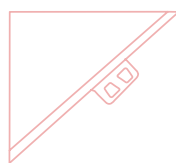

---

Hand Controllers 90





---

Standing Desk Mats 95



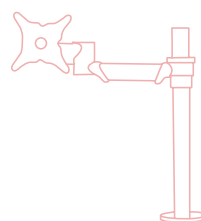

---

Cable Ports & Clips 91

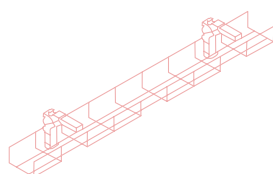

---

Monitor Arms 96





---

Cable Management 92

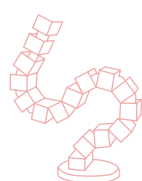

---

In Desk Power 98





---

Cable Spines/Castors 93

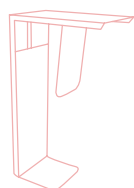

---

Modesty Panels 100



---

CPU Holders 94

# HAND CONTROLLERS



Standard issue hand controller

All desks are supplied with a standard issue up/down hand control switch as pictured above. For those requiring a specific height setting memory, or wanting an LCD display of height in centimeters, we also have the option to upgrade to a 4 way height settable memory controller.



4 Way Programmable Memory Control

## 4 WAY MEMORY CONTROLLER

Dimensions

**135mm x 25mm**

Guarantee

**5 Yrs**

LCD Display

**Yes**

Height Settable

**Yes**

Height Settings

**4**

Compatibility

**All desk models**

CON4/ADV

## CABLE PORTS & CLIPS



To manage cable routing and access, we offer cable ports as an option for all desk models. These can be situated in any position specified by the client, and are processed to order with our in-house CNC machinery. This allows a truly bespoke offering to cater for exact requirements.



Cable Tidy Port

Black

CP/BLA



Cable Tidy Port

Grey

CP/GRY



Cable Tidy Port

White

CP/WHI



Cable Clips - Pack of Four

Grey

GCC

# CABLE MANAGEMENT



Lavoro offer a range of cable management trays and cable baskets for use on all desk models. These can be either mounted directly on the frames of our Advance and Duo models, or top fixed to all other ranges.



## Advance Cable Management Tray System

Telescopic to suit all desks  
Fixes directly to frame  
Suitable for all Advance and Duo Desks

## Advance Cable Management Tray System

Telescopic to suit all desks  
Fixes directly to frame  
Suitable for all Advance and Duo Desks

Black

BCT/ADV

Silver

SCT/ADV

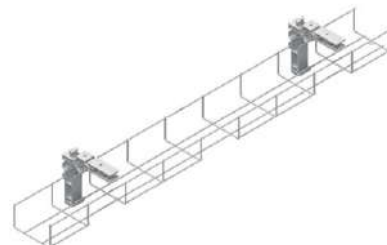

## Advance Cable Management Tray System

Telescopic to suit all desks  
Fixes directly to frame  
Suitable for all Advance and Duo Desks

## Pathway Cable Tray

Fixes directly into underside of desk top  
Suitable for all Lavoro desks

White

WCT/ADV

600mm

PWY/600

900mm

PWY/900

1200 mm

PWY/1200

## CABLE SPINES

To safely route all power and data cabling to the floor, we offer an easy-assemble cable spine option, available in black, white and silver to compliment our desk ranges. These spines will facilitate any height adjustable desk of up to 1300mm in height, and have removable segments, which enables them to be shortened if required.



---

Cable Spine

---

Black

---

BCS/PRO



---

Cable Spine

---

Silver

---

SCS/PRO



---

Cable Spine

---

White

---

WCS/PRO

## CASTORS

All Lavoro height adjustable desks are castor compatible, increasing workplace flexibility.



---

Castors

---

Black

---

CAS/M8



# CPU HOLDERS



As a space saving and secure way to house computer processor units, we offer a CPU holder with quick release height and width adjustment. This is supplied with fixings to allow mounting directly to the underside of any of the Lavoro desk ranges.



CPU Holder

Black



CPU Holder

BCPU

Silver

SCPU



CPU Holder

White

WCPU



## STANDING DESK MATS



Standing desk mats offer relief of pressure on the spine for any user spending prolonged periods of time on their feet, and are proved to aid the increase of blood circulation. This makes them an ergonomic benefit to all height adjustable desk users. These mats also feature a bevelled edge to enable the traversing of castors and increase the aesthetic appeal of the mat.

### PRODUCT DETAILS

Available sizes

450 x 750mm/600 x 900mm

Anti-Fungal

Yes

Anti-Microfibal

Yes

Profile

Bevelled Edge

Material

**Rubber**



Standing Desk Mat - Black

450 x 700mm

SM450700

600 X 900mm

SM600900

# MONITOR ARMS

An ergonomic must-have for all desk users, our highly adjustable monitor arms provide a simple and minimalistic approach to monitor placement and are all supplied with through desk and top clamp fixing options. Our monitor arms are also VESA compatible for both 75mm and 100mm options.

## PRODUCT DETAILS

Weight Capacity	Through Desk Fix
Single - 20Kg Twin - 26Kg (13Kg Per Arm)	Yes
Adjustable Height	Pole Height
Yes (8 - 75mm)	410mm
Veesa Plate Fixing	Maximum Arm Reach
Universal 75mm & 100mm	455mm
Top Clamp Fix	Integrated Cable Management
Yes	Yes



Single Monitor Arm

Silver

MA1/SIL



Single Monitor Arm

White

MA1/WHI



Single Monitor Arm

Black

MA1/BLA



Double Monitor Arm

Silver

MA2/SIL



Double Monitor Arm

White

MA2/WHI



Double Monitor Arm

Black

MA2/BLA



# IN DESK POWER

Our in desk and under desk power units provide an organised and efficient source of power, minimising cabling and safely consolidating power distribution. Available with USB A and C smart charge functions, or just simply as a three pin UK socket. All power units are also supplied with an integrated spare fuse.

## PRODUCT DETAILS

Weight Capacity	Top Fix
Single – 20Kg Twin – 26Kg (13Kg Per Arm)	Yes
Adjustable Height	Through Desk Fix
Yes (8 – 75mm)	Yes
Veesa Plate Fixing	Clamp Fix
75 X 10Mm	Yes

## POWER MODULE WITH 3 PIN UK SOCKET



In Desk Power

White

PM1S/WHI

In Desk Power

Black

PM1S/BLA

## POWER MODULE WITH 3 PIN UK SOCKET AND TWIN USB SMART CHARGE



In Desk Power  
With USB + Twin Smart Charge

White

PM1USB/WHI

In Desk Power  
With USB + Twin Smart Charge

Black

PM1USB/BLA



## UNDER DESK EXTENSION BLOCKS



2 Gang

UPM2



3 Gang

UPM3



4 Gang

UPM4

## LEADS/CONNECTORS

WSC2000

Power Cable - 2m

WCC500

Connector Lead - 0.5m

WSC4000

Power Cable - 3m

WCC1000

Connector Lead - 1m

WSC5000

Power Cable - 5m

WCC1500

Connector Lead - 1.5m

WCC2000

Connector Lead - 2m



# MODESTY PANELS

A comprehensive range of 18mm modesty panels in matching decors to all of our stock desk tops. These are supplied with brackets in black, white and silver to compliment all frame colours and styles.



## AVAILABLE SIZES

1000 x 400	MP1000400***
1200 x 400	MP1200400***
1400 x 400	MP1400400***
1600 x 400	MP1600400***

## Brackets

Black	MPBB
Silver	MPBS
White	MPBW

*(Replace \*\*\* with required colour)*

Our modesty panels are supplied with fixing brackets.  
Custom sizes/colours available.



## SCREENS & DUO ACCESSORIES

We provide high quality acoustic screens to compliment all desk ranges and configurations. These are made to order to clients' exact specifications, and our capable internal sales team are equipped to assist with this process. All screens are provided with the appropriate fixing brackets.



Universal powder-coated screen bracket for use with Duo desks, supplied with fixing to connect directly on the frame.

### Brackets

Black	BRK/BDUO
Silver	BRK/SDUO
White	BRK/WDUO

### Lower Cable Trays

Black	LNKTRY/BDUO
Silver	LNKTRY/SDUO
White	LNKTRY/WDUO

### Desk Link Bars

Black	LNKBAR/BDUO
Silver	LNKBAR/SDUO
White	LNKBAR/BDUO





## DELIVERY

We offer free next day delivery, for all orders within mainland UK.

Charges may apply for highlands and outer islands.

All stock orders placed before 12.00 noon will be delivered on the following working day and will be free of charge.

For dedicated deliveries, we can offer the following services:

- > AM Delivery
- > Saturday Delivery
- > Timed Delivery

We use reputable and trusted couriers to ensure that your desks arrive in perfect condition. This will be a kerbside delivery service.

Deliveries can also be shipped with customers' own paperwork.



# INSTALLATION

If you require your desk to be installed, we also provide an installation service all over the UK. We have three grades of installation service that we can offer:



## Silver

Goods are delivered next day or dedicated day. We will provide an installation date on confirmation of order, which will be within 10 working days of delivery. Two qualified fitters will arrive on the specified day to build and commission your furniture. Please note, this service does not include disposal of packaging.

CODE - INS/SIL



## Gold (most popular)

Our advisors will work with you to determine the ideal installation date. We will send a team of qualified and insured installers, who will deliver, build and commission your furniture, and take away all packaging.

CODE - INS/GOL



## Platinum

Suitable for larger projects, one of our experienced in-house product specialists will oversee a team of installers to deliver, install and commission your furniture. With this service, we can also tie in installation of any supplementary products from other manufacturers. All products will be tested prior to job sign-off.

CODE - INS/PLA

We make life easy by arranging the installation for you. Our expert fitters are an experienced & competent team.

# MARKETING SUPPORT



## HOW CAN WE ASSIST YOU?

We can support your sales process by providing any of the following, on request;

### **Link to full bank of images**

We can provide you with our Dropbox link to all images of our full product range, including accessories and lifestyle images.

### **Demo videos**

From how to assemble a desk to fitting a cable management system, our demo videos are a helpful guide to provide customer support, both before and after the customer has received the desk.

### **Personalised images**

If you have a requirement for images of a bespoke top or frame, our designers can work with you to produce them.

### **Additional catalogues / price lists**

On request we can send extra copies of our catalogue & trade price list either in the post or via email. Just let us know!

### **CAD Files**

When quoting for a large project or office fit out, dimensions and sizes of desks play a crucial part in your planning. All of our frame styles are available in 2D and 3D CAD formats.

### **Showroom literature**

To assist salespersons in your showroom, we are happy to provide additional, unpriced catalogues and assistance with hard copy and web based marketing resources.

### **Demonstrations**

We can arrange for one of our sales executives to bring a desk to you or your customer. Please contact our team, who will be happy to assist you.

## PRODUCTION

All of our components are made in the UK and Europe, with each desk top being fitted with metal-to-metal fixings using our specialist CNC machinery. This ensures that the desks are simple to build, and gives the strongest possible construction.

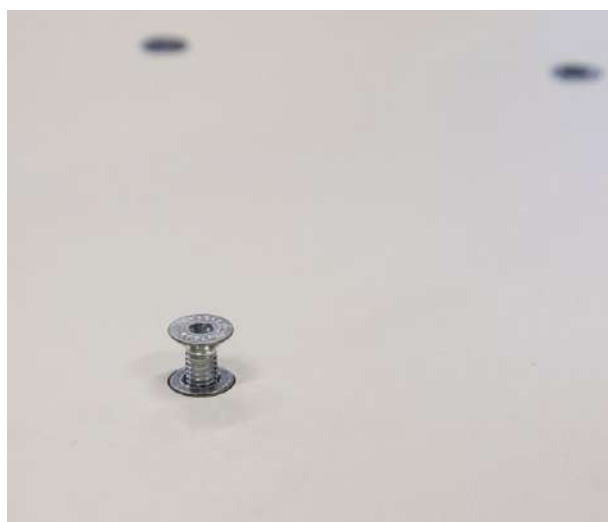

# ENVIRONMENTAL POLICY

Lavoro recognises that it has a responsibility to the environment beyond legal and regulatory requirements. We are committed to reducing our environmental impact and continually improving our environmental performance as an integral part of our business strategy and operating methods. We will encourage customers, suppliers and other stakeholders to do the same. This Environmental Policy sets out our aims.

## RESPONSIBILITY

Brent Simpson, Managing Director, is responsible for ensuring that this environmental policy is implemented, however, all employees have a responsibility in their area to ensure that the aims and objectives of this policy are met.

Our height adjustable desk ranges are all carefully selected as being efficient with use of energy, and low impact on the environment. Each desk uses less than 0.3W when on standby and have a max duty cycle of 2 minutes on/18 minutes off.

## POLICY AIMS

We will:

- Comply with all relevant regulatory requirements in the height adjustable desk industry.
- Continually improve and monitor environmental performance of our height adjustable desks.
- Continually improve and reduce environmental impacts of all aspects of our company.
- Incorporate environmental factors into business decisions
- Increase employee awareness and training.

## PAPER

We will:

- Minimise the use of paper in the office, through software, staff training and awareness.
- Reduce packaging as much as possible.
- Seek to buy recycled and recyclable paper products.
- Reuse and recycle all paper where possible.

## ENERGY AND WATER

We will seek to:

- Reduce the amount of energy used as much as possible.
- Switch off lights and electrical equipment when not in use.
- Adjust heating with energy consumption in mind.
- Take energy consumption and efficiency of new height adjustable desks into consideration before releasing them to the open market.

## OFFICE SUPPLIES

We will:

- Evaluate if the need can be met in another way.
- Evaluate the environmental impact of any new products we intend to purchase.
- Favour more environmentally friendly and efficient products wherever possible.
- Reuse and recycle everything we can.

## TRANSPORTATION

We will:

- Promote the use of travel alternatives such as e-mail or video/phone conferencing.
- Make additional efforts to accommodate the needs of those using public transport or bicycles.
- Favour 'green' vehicles and maintain them rigorously to ensure ongoing efficiency.

## MAINTENANCE AND CLEANING

We will:

- Use cleaning materials that are as environmentally friendly as possible when cleaning our height adjustable desks, and all on-site cleaning requirements.
- Use materials in any office refurbishment that are as environmentally friendly as possible.
- Only use licensed and appropriate organisations to dispose of waste.

## MONITORING AND IMPROVEMENT

We will:

- Comply with all relevant regulatory requirements.
- Continually improve and monitor environmental performance.
- Continually improve and reduce environmental impacts.
- Incorporate environmental factors into business decisions.
- Increase employee awareness through training.
- Review this policy and any related business issues at management meetings.

## CULTURE

We will:

- Update this environmental policy at least once annually in consultation with staff and other stakeholders where necessary.
- Involve staff in the implementation of this policy, for greater commitment and improved performance.
- Work with suppliers, contractors and subcontractors to improve their environmental performance.
- Use local labour and materials where available to reduce CO2 and help the community.









---

# TERMS & CONDITIONS

## 1. Interpretation

1.1 The definitions and rules of interpretation in this condition apply in these conditions. Business Day: a day (other than a Saturday, Sunday or public holiday) when banks in London are open for business; Buyer: the person, firm or company who purchases the Goods from the Supplier; Supplier: collectively Cambrian Marketing Limited and Lavoro Design Limited, all trading as LAVORO, a partnership having its principal office at Unit 38 Mochdre Industrial Estate, Newtown, Powys SY16 4LE; Contract: any contract between the Supplier and the Buyer for the sale and purchase of the Goods; Delivery Point: the place where delivery of the Goods is to take place under condition 4; Goods: any goods agreed in the Contract to be supplied to the Buyer by the Supplier (including any part(s) of them); Limit of Indemnity: currently the maximum amount of £2,000,000 for all occurrences during any one period of insurance; VAT: value added tax chargeable under English law for the time being and any similar additional tax. Reference to a law is reference to it as it is in force for the time being taking account of any amendment, extension, application or re-enactment and includes any subordinate legislation for the time being in force made under it. Words in the singular include the plural and vice versa. Reference to one gender includes reference to the other. Condition headings do not affect the interpretation of these conditions.

## 2. Application of Terms

2.1 Subject to any variation under condition 2.3 the Contract shall be on these conditions to the exclusion of all other terms and conditions (including any terms or conditions which the Buyer purports to apply under any purchase order, confirmation of order, specification or other document).

2.2 No terms or conditions endorsed on, delivered with or contained in the Buyer's purchase order, confirmation of order, specification or other document shall form part of the Contract as a result of such document being referred to in the Contract.

2.3 These conditions apply to all the Supplier's sales and any variation to these conditions and representations about the Goods shall have no effect unless expressly agreed in writing and signed by a partner of the Supplier. The Supplier's sales representatives have no authority to accept, vary or amend any of these conditions. The Buyer acknowledges that it has not relied on any statement, promise or representation made or given by or on behalf of the Supplier which is not set out in the Contract. Nothing in this condition shall exclude or limit the Supplier's liability for fraudulent misrepresentation.

2.4 Each order or acceptance of a quotation for Goods by the Buyer from the Supplier shall be deemed to be an offer by the Buyer to buy Goods subject to these conditions.

2.5 No order placed by the Buyer shall be deemed to be accepted by the Supplier until a written acknowledgement of order is issued by the Supplier or (if earlier) the Supplier delivers the Goods to the Buyer.

2.6 The Buyer shall ensure that the terms of its order and any applicable specification are complete and accurate.

2.7 Any quotation is given on the basis that no Contract shall come into existence until the Supplier despatches an acknowledgement of order to the Buyer. Any quotation is valid for the period set out on the quotation or, in the absence thereof, for 30 days, provided that the Supplier has not previously withdrawn it.

## 3. Description

3.1 The quantity and description of the Goods shall be as set out in the Supplier's quotation or acknowledgement of order.

3.2 All samples, drawings, descriptive matter, specifications and advertising issued by the Supplier and any descriptions or illustrations contained in the Supplier's catalogues or brochures are issued or published for the sole purpose of giving an approximate idea of the Goods described in them. They shall not form part of the Contract and this is not a sale by sample.

## 4. Delivery

4.1 Unless otherwise agreed in writing, delivery of the Goods shall take place on the arrival of the Goods at the Buyer's usual place of business. Unless otherwise agreed in writing, the cost of delivery of the Goods is not included in the price for the Goods. The Supplier reserves the right to make such charge associated with the delivery of the Goods as stated in the Supplier's catalogue published on the date of delivery or deemed delivery, or if no such price is published, as set out in the invoice for the Goods.

4.2 Any dates specified by the Supplier for delivery of the Goods are an estimate and time for delivery shall not be made of the essence by notice. If no dates are specified, delivery shall be within a reasonable time.

4.3 Subject to the other provisions of these conditions the Supplier shall not be liable for any direct, indirect or consequential loss (all three of which terms include, without limitation, pure economic loss, loss of profits, loss of business, depletion of goodwill and similar loss), costs, damages, charges or expenses caused directly or indirectly by any delay in the delivery of the Goods (even if caused by the Supplier's negligence), nor shall any delay entitle the Buyer to terminate or rescind the Contract or reject further deliveries unless such delay exceeds two months.

4.4 If for any reason the Buyer fails to accept delivery of any of the Goods, or the Supplier is unable to deliver the Goods on time because the Buyer has not provided appropriate instructions, documents, licences or authorisations: (a) risk in the Goods shall pass to the Buyer (including for loss or damage caused by the Supplier's negligence); and (b) the Goods shall be deemed to have been delivered; or (c) the Supplier may store the Goods until delivery, whereupon the Buyer shall be liable for all related costs and expenses (including, without limitation, storage and insurance).

4.5 The Buyer shall provide at the Delivery Point and at its expense adequate and appropriate equipment and manual labour for loading or unloading of the Goods.

4.6 The Supplier may cancel delivery if it believes it would be unsafe, unlawful or unnecessarily difficult to deliver to the Delivery Point and delivery shall take place upon the return of the Goods to the Supplier's place of business.

4.7 The Supplier may deliver the Goods by separate instalments. Each separate instalment shall, subject to condition 4.8, be invoiced and paid for in accordance with the provisions of the Contract. 4.8 Each instalment shall be a separate Contract and no cancellation or termination of any one Contract relating to an instalment shall entitle the Buyer to repudiate or cancel any other Contract or instalment.

## 5. Non-Delivery

5.1 The quantity of any consignment of Goods as recorded on despatch from the Supplier's place of business shall be conclusive evidence of the quantity received on delivery unless the Buyer can provide conclusive evidence proving the contrary.

5.2 The Supplier shall not be liable for any non-delivery of Goods (even if caused by the Supplier's negligence) unless the Buyer gives written notice to the Supplier of the non-delivery within 7 days of the date when the Goods would in the ordinary course of events have been delivered.

5.3 Any liability of the Supplier for non-delivery of the Goods shall be limited to replacing the Goods within a reasonable time or issuing a credit note at the pro rata Contract rate against any invoice raised for such Goods.

## 6. Risk/Title

6.1 The Goods are at the risk of the Buyer from the time of delivery.

6.2 Where applicable, risk in transit shall remain with the Supplier until delivery at the Delivery Point provided that in the event of any damage to the Goods during transit the Supplier will replace any goods proved to the Supplier's satisfaction to have been damaged in transit subject to having received from the Buyer within 48 hours after delivery notification in writing of the occurrence of the damage

and also, if and so far as practicable, of its nature and extent.

6.3 Ownership of the Goods shall not pass to the Buyer until the Supplier has received in full (in cash or cleared funds) all sums due to it in respect of: (a) the Goods; and (b) all other sums which are or become due to the Supplier from the Buyer.

6.4 Until ownership of the Goods has passed to the Buyer, the Buyer shall: (a) hold the Goods on a fiduciary basis as the Supplier's bailee; (b) store the Goods (at no cost to the Supplier) separately from all other goods of the Buyer or any third party in such a way that they remain readily identifiable as the Supplier's property; (c) not destroy, deface or obscure any identifying mark or packaging on or relating to the Goods; and (d) maintain the Goods in satisfactory condition and keep them insured on the Supplier's behalf for their full price against all risks to the reasonable satisfaction of the Supplier. On request the Buyer shall produce the policy of insurance to the Supplier.

6.5 The Buyer may resell the Goods before ownership has passed to it solely on the following conditions: (a) any sale shall be effected in the ordinary course of the Buyer's business at full market value; and (b) shall be a sale of the Supplier's property on the Buyer's own behalf and the Buyer shall deal as principal when making such a sale.

6.6 The Buyer's right to possession of the Goods shall terminate immediately if: (a) any of the matters set out in condition 11.1 (a) to (o) occur; or (b) the Buyer encumbers or in any way charges any of the Goods.

6.7 The Supplier shall be entitled to recover payment for the Goods notwithstanding that ownership of any of the Goods has not passed from the Supplier.

6.8 The Buyer grants the Supplier its agents and employees an irrevocable licence at any time to enter any premises where the Goods are or may be stored in order to inspect them or where the Buyer's right to possession has terminated, to recover them.

6.9 Where the Supplier is unable to determine whether any Goods are the goods in respect of which the Buyer's right to possession has terminated, the Buyer shall be deemed to have sold all goods of the kind sold by the Supplier to the Buyer in the order in which they were invoiced to the Buyer.

6.10 On termination of the Contract the Supplier's (but not the Buyer's) rights in this condition 6 shall remain in effect.

### 7. Price

7.1 Unless otherwise agreed by the Supplier in writing, the price for the Goods shall be the price set out in the Supplier's price list published on the date of delivery or deemed delivery.

7.2 The price for the Goods shall be exclusive of any VAT which the Buyer shall pay when it is due to pay for the Goods.

7.3 The Supplier reserves the right, by giving written notice to the Buyer at any time before delivery, to increase the price of the Goods to reflect any increase in the cost to the Supplier which is due to any factor beyond the reasonable control of the Supplier (including without limitation, any increase in packaging, insurance, transportation costs, costs of labour, materials or other costs of manufacture, taxes, tariffs or import duties (where applicable) or changes in legislation or regulations) or any changes in delivery dates, quantities or specifications for the Goods which are requested by the Buyer or any delay caused by failure of the Buyer to give the Supplier adequate information or instructions.

7.4 The Buyer agrees and acknowledges that the price for the Goods is based upon the limitations of liability set out in conditions 3 and 10 and upon the limited warranties given in condition 9.

### 8. Payment

8.1 Subject to condition 8.4 and unless otherwise agreed by the Supplier in writing, payment of the price for the Goods is due by the later of: (i) the delivery or deemed delivery of the Goods; and (ii) the issue to the Buyer of the invoice in respect of the Goods.

8.2 Time for payment shall be of the essence.

8.3 No payment shall be deemed to have been received

until the Supplier has received cleared funds.

8.4 All payments payable to the Supplier under the Contract shall become due immediately on its termination.

8.5 The Buyer shall make all payments due under the Contract in full without any deduction whether by way of set-off, counterclaim, discount, abatement or otherwise unless the Buyer has a valid court order requiring an amount equal to such deduction to be paid by the Supplier to the Buyer. The Buyer shall not be entitled to withhold any payments due under the Contract because of a disputed claim of any nature.

8.6 If the Buyer fails to pay the Supplier any sum due pursuant to the Contract:

8.6.1 the Buyer shall be liable to pay interest to the Supplier on such sum from the due date for payment at the annual rate of 4% above the base lending rate from time to time of HSBC, accruing on a daily basis until payment, before or after any judgment but the Supplier reserves the right to interest under the Late Payment of Commercial Debts (Interest) Act 1998; and  
8.6.2 the Supplier shall be entitled to suspend or cancel all future deliveries of Goods to the Buyer.

8.7 In the event that any variation is agreed between the Supplier and the Buyer regarding payment terms, which results in credit terms being extended to the Buyer, any such variation will cease and the amount of any debt owed will be payable forthwith on the occurrence of any of the matters set out in condition 11.1 (a) to (o).

8.8 Without prejudice to any other right or remedy of the Supplier, any payment by the Buyer, which results in a cheque being referred to the drawer for whatever reason, will incur a charge of £50.00 plus VAT per cheque payable by the Buyer.

8.9 The Supplier may apply all or any part of any sum owing by the Supplier its subsidiaries or associates to the Buyer in relation to any matter in or towards payment of any sum owing to the Supplier. For this purpose references to the Supplier or the Buyer include any company which is a holding company, subsidiary or associate of the Supplier or the Buyer respectively.

8.10 The Supplier may appropriate any payment made by the Buyer to the Supplier against amounts that are owed by the Buyer to the Supplier for the longest period not withstanding any prior appropriation of that payment by the Buyer.

### 9. Quality

9.1 The Supplier warrants that (subject to the other provisions of these conditions) on delivery the Goods shall: (a) be of satisfactory quality within the meaning of the Sale of Goods Act 1979; (b) be reasonably fit for any particular purpose for which the Goods are being bought if the Buyer had made known that purpose to the Supplier in writing and the Supplier has confirmed in writing that it is reasonable for the Buyer to rely on the skill and judgement of the Supplier. For the avoidance of doubt, the warranties given in this condition 9.1 are given in lieu and exclude the operation of the implied terms as to satisfactory quality and fitness for purpose in the Sale of Goods Act 1979, to the fullest extent permitted by law.

9.2 The Supplier shall not be liable for a breach of any of the warranties in condition 9.1 unless: (a) the Buyer gives written notice of the defect to the Supplier within 14 days of the time when the Buyer discovers or ought to have discovered the defect, whichever is the earlier, and in any event within one year following the delivery or deemed delivery of the Goods; and (b) the Supplier is given a reasonable opportunity after receiving the notice of the defect from the Buyer of examining such Goods and the Buyer (if asked to do so by the Supplier) returns such Goods to the Supplier's place of business for the examination to take place there.

9.3 The Supplier shall not be liable for a breach of any of the warranties in condition 9.1 if: (a) the Buyer makes any further use of such Goods after giving such notice; or (b) the defect arises because the Buyer failed to follow the Supplier's oral or written instructions as to the storage, installation, commissioning, use or maintenance of the Goods or (if

---

## TERMS & CONDITIONS

there are none) good trade practice; or (c) the Buyer carries out repairs itself or brings about changes in the nature, composition or packaging of the Goods delivered, or has these carried out or brought about by third parties, or if the Goods delivered are used improperly or for any purpose other than that for which they are meant or are maintained and/or stored improperly or contrary to any agreed or legal regulations or if the defect of the Goods can be ascribed to the other party in any way.

9.4 Subject to condition 9.2 and 9.3, if any of the Goods do not conform with any warranties in condition 9.1 the Supplier shall at its option repair or replace such Goods (or the defective part) or refund the price of such Goods at the pro rata Contract rate provided that, if requested, the Buyer shall return the Goods or the part of such Goods which is defective to the Supplier.

9.5 If the Supplier complies with condition 9.4 it shall have no further liability for a breach of any of the warranties in condition 9.1 in respect of such Goods and any Goods replaced shall belong to the Supplier.

9.6 Subject to the other provisions of these conditions the Supplier shall not be liable for any direct, indirect or consequential loss (all three of which terms include, without limitation, pure economic loss, loss of profits, loss of business, depletion of goodwill and similar loss), costs, damages, charges or expenses caused directly or indirectly by the unsuitability of any site at which the Goods are installed or any installation procedures relating to the Goods.

9.7 Where the Goods sold are manufactured by the Supplier to the Buyer's specification, or are outside the Supplier's normal range, or are sourced by the Supplier at the Buyer's request, the Supplier's obligation is limited to manufacturing or sourcing such Goods within the specifications provided by the Buyer (except to the extent the Supplier in its own discretion has decided to vary the same, taking into account the current custom and practice) and the Buyer shall otherwise have no right to reject such Goods or to cancel an order in respect of such Goods.

### 10. Limitation of Liability

10.1 Subject to conditions 4, 5 and 9, the following provisions set out the entire financial liability of the Supplier, which for the avoidance of doubt and for the purposes of this condition 10 shall mean the collective aggregate liability of all the partners in the Supplier (including any liability for the acts or omissions of its employees, agents and sub-contractors), to the Buyer in respect of: (a) any breach of these conditions; (b) any use made or resale by the Buyer of any of the Goods, or of any product incorporating any of the Goods; and (c) any representation, statement or tortious act or omission including negligence arising under or in connection with the Contract.

10.2 All warranties, conditions and other terms implied by statute or common law (save for the conditions implied by section 12 of the Sale of Goods Act 1979 or section 2(3) of the Supply of Goods and Services Act 1982, whichever Act applies to the Contract) are, to the fullest extent permitted by law, excluded from the Contract.

10.3 Nothing in these conditions excludes or limits the liability of the Supplier: (a) for death or personal injury caused by the Supplier's negligence; or (b) under section 2(3) Consumer Protection Act 1987; or (c) for any matter which it would be illegal to attempt to exclude its liability; or (d) for fraud or fraudulent misrepresentation.

10.4 Subject to condition 10.2 and condition 10.3 the Supplier's total liability in contract, tort (including negligence or breach of statutory duty), misrepresentation, restitution or otherwise, arising in connection with the performance or contemplated performance of the Contract shall be limited to the Contract price plus 100% or the sum of £50,000 (whichever is the greater).

10.5 In the event that the limitation on liability set out in condition 10.4 is found by any court, tribunal or administrative body of competent jurisdiction to be illegal, invalid, void, voidable, unenforceable or unreasonable then subject to condition 10.2 and condition 10.3 the Supplier's total liability in contract, tort (including negligence or

breach of statutory duty), misrepresentation, restitution or otherwise, arising in connection with the performance or contemplated performance of the Contract shall be limited to the Limit of Indemnity remaining from time to time in accordance with the Supplier's public/products liability insurance effected by the Supplier, a copy of which policy shall be provided to the Buyer on request.

10.6 Subject to condition 10.2 and 10.3 the Supplier shall not be liable to the Buyer for loss of profit, loss of business, or depletion of goodwill in each case whether direct, indirect or consequential, or any claims for consequential compensation whatsoever (howsoever caused) which arise out of or in connection with the Contract.

### 11. Termination

11.1 The Supplier may terminate the Contract without liability to the Buyer immediately (or following such period as it sees fit) by giving notice to the Buyer if: (a) the Buyer fails to pay any amount due under the Contract on the date for payment and remains in default for more than 7 days; or (b) the Buyer commits a breach of any term of the Contract and (if remediable) fails to remedy that breach in 14 days; or (c) the Buyer repeatedly breaches any of the Contract in such a manner as to reasonably justify the opinion that its conduct is inconsistent with having the intention or ability to give effect to the terms of the Contract; or (d) the Buyer suspends or threatens to suspend payment of its debts or is unable to pay its debts as they fall due or admits inability to pay its debts or is deemed either unable to pay its debts (being a company within the meaning of section 123 of the Insolvency Act 1986) or as having no reasonable prospect of so doing within the meaning of section 268 of the Insolvency Act 1986 or in the case of a partnership has any partner to whom foregoing applies; or (e) the Buyer commences negotiations with any of its creditors with a view to rescheduling any of its debts, or makes a proposal for or enters into any compromise or arrangement with its creditors; or (f) a petition is filed, a notice is given, a resolution is passed, or an order is made, for or in connection with the winding up of the Buyer; or (g) an application is made to court, or an order is made, for the appointment of an administrator or if a notice of intention to appoint an administrator is given or if an administrator is appointed over the Buyer; or (h) a floating charge holder over the assets of the Buyer has become entitled to appoint or has appointed an administrative receiver; or (i) a person becomes entitled to appoint a receiver over the assets of the Buyer or a receiver is appointed over the assets of the Buyer; or (j) the Buyer, being an individual, is the subject of a bankruptcy petition or order; or (k) a creditor or encumbrancer of the Buyer attaches or takes possession of, or a distress, execution, sequestration or other such process is levied or enforced on or sued against, the whole or any part of its assets and such attachment or process is not discharged within 14 days; or (l) any event occurs, or proceeding is taken, with respect to the Buyer in any jurisdiction to which it is subject that has an effect equivalent or similar to any of the events mentioned in condition 11.1(d) to condition 11.1(k) (inclusive); or (m) the Buyer suspends or ceases, or threatens to suspend or cease, to carry on all or a substantial part of its business; or (n) the Buyer, being an individual, dies or, by reason of illness or incapacity (whether mental or physical), is incapable of managing his or her own affairs or becomes a patient under any mental health legislation; or (o) there is a change of control of the Buyer.

11.2 In the event of termination in accordance with condition 11.1 or of any order being cancelled by the Buyer, the Buyer shall indemnify the Supplier against all loss (including profits) costs (including labour and overheads) and all other expenses and damages reasonably and properly incurred by the Supplier in connection with the Contract and its termination.

### 12. Assignment

12.1 The Supplier may assign the Contract or any part of it to any person, firm or company.



12.2 The Buyer shall not be entitled to assign the Contract without the prior written consent of the Supplier. The Supplier shall not be deemed to have accepted an assignment of the Contract due to any circumstance or pursuant to any act or omission of the Supplier including, without limitation, the acceptance of payments or obligations under the Contract from a third party.

### 13. Force Majeure

The Supplier reserves the right to defer the date of delivery or to cancel the Contract or reduce the volume of the Goods ordered by the Buyer (without liability to the Buyer) if it is materially prevented from or delayed in the carrying on of its business due to circumstances beyond the reasonable control of the Supplier including, without limitation, acts of God, governmental or regulatory actions (including orders preventing the movement of Goods), changes in legislation or codes of practice, war or national emergency, acts of terrorism, protests, riot, civil commotion, fire, explosion, flood, epidemic, lock-outs, strikes or other labour disputes (whether or not relating to either party's workforce), failure of sub-contractors or restraints or delays affecting carriers or inability or delay in obtaining supplies of adequate or suitable materials, provided that, if the event in question continues for a continuous period in excess of six months, the Buyer shall be entitled to give notice in writing to the Supplier to terminate the Contract.

### 14. Returns Policy

14.1 Without prejudice to clauses 4, 5, 9 and 10, or the statutory rights of the Buyer: (a) any Goods returned which are not included in the Supplier's catalogue and have been obtained by the Supplier at the request of the Buyer will only be refunded in the absolute discretion of the Supplier; (b) in respect of any Goods returned where Orders are placed via mail, phone, fax or the internet, which have been cancelled within seven days of receiving the Goods, the Supplier will refund the price of the Goods in full; (c) where an Order has been cancelled within 28 days of receiving the Goods, the Supplier will examine the returned Goods within a reasonable time. Where Goods are found to be defective, the price of the Goods will be refunded in full (d) where Goods returned in accordance with clause 14.1(c) are found not to be defective, the Supplier reserves the right to deduct a re-stocking charge of 20% of the Price of the Goods from any refund to the Buyer. 1

4.2 All Goods must be returned unused, in their original packaging and in a re-saleable condition (to be determined in the Supplier's absolute discretion) and the Buyer will be responsible for the costs of returning the Goods to the Supplier and for arranging the return of the Goods to the Supplier. Costs of delivery to the Buyer (if any) will not be refunded.

### 15. General

15.1 Each right or remedy of the Supplier under the Contract is without prejudice to any other right or remedy of the Supplier.

15.2 If any provision of the Contract is found by any court, tribunal or administrative body of competent jurisdiction to be wholly or partly illegal, invalid, void, voidable, unenforceable or unreasonable it shall to the extent of such illegality, invalidity, voidness, voidability, unenforceability or unreasonableness be deemed severable and the remaining provisions of the Contract and the remainder of such provision shall continue in full force and effect.

15.3 Failure or delay by the Supplier in enforcing or partially enforcing any provision of the Contract shall not be construed as a waiver of any of its rights under the Contract.

15.4 Any waiver by the Supplier of any breach of, or any default under, any provision of the Contract by the Buyer shall not be deemed a waiver of any subsequent breach or default and shall in no way affect the other terms of the Contract.

15.5 The parties to the Contract do not intend that any term of the Contract shall be enforceable by virtue of the Contracts (Rights of

Third Parties) Act 1999 by any person that is not a party to it.

15.6 The formation, existence, construction, performance, validity and all aspects of the Contract shall be governed by English law and the parties submit to the exclusive jurisdiction of the English courts.

### 16. Communications

16.1 All communications between the parties about the Contract shall be in writing and delivered by hand or sent by pre-paid first class post or sent by fax: (a) (in case of communications to the Supplier) to its principal office or such changed address as shall be notified to the Buyer by the Supplier; or (b) (in the case of the communications to the Buyer) to the registered office of the addressee (if it is a company) or (in any other case) to any address of the Buyer set out in any document which forms part of the Contract or such other address as shall be notified to the Supplier by the Buyer.

16.2 Communications shall be deemed to have been received: (a) if sent by pre-paid first class post, two days (excluding Saturdays, Sundays and holidays) after posting (exclusive of the day of posting); or (b) if delivered by hand, on the day of delivery; or (c) if sent by fax on a working day prior to 4.00 pm, at the time of transmission, otherwise the next working day.

16.3 Communications addressed to the Supplier shall be marked for the attention of a partner or the partners of the Supplier.

### 17. Confidentiality

The Buyer shall keep confidential and shall not without the prior consent in writing of the Supplier disclose to any third-party any technical or commercial information which it has acquired from the Supplier as a result of discussions, negotiations and other communications between them relating to the Goods and the Contract.

### 18. Direct Debit

In the event that the Supplier agrees with the Buyer in writing that Goods shall be paid for by Direct Debit, the Buyer shall comply with the provisions of such agreement and shall execute and deliver to the Supplier all such documents (including any Direct Debit mandate or instruction to a bank or building society) as the Supplier shall request in order to give effect to such agreement.

---

NOTES







[www.lavorodesign.com](http://www.lavorodesign.com)

**Contact**  
0330 133 1112  
[info@lavorodesign.com](mailto:info@lavorodesign.com)

**Head Office**  
85, Mochdre Industrial Estate,  
Newtown, SY16 4LE

**London Office**  
167 City Road  
London, EC1V 1AW